

Product Specifications

Customer	
Description	5.7" TFT LCD Module with Touch Panel
Model Name	OSD057AC213
Date	2006/07/26
Doc. No.	
Revision	02

Customer Approval	
Date	
<p>The above signature represents that the product specifications, testing regulation, and warranty in the specifications are accepted</p>	

		Design Engineering		
		Approval	Check	Design
		宋 一 七 W	王 顏 若 燕	林 作 榮

CONTENTS

No.	ITEM	PAGE
0	RECORD OF REVISION	3
1	SUMMARY	4
2	FEATURES	4
3	GENERAL SPECIFICATIONS	4
4	ABSOLUTE MAXIMUM RATINGS	4
5	ELECTRICAL CHARACTERISTICS	5
6	TOUCH PANEL	7~8
7	AC CHARACTERISTICS	9~11
8	WAVEFORM	12~20
9	OPTICAL CHARACTERISTICS	21
10	BLOCK DIAGRAM	25
11	INPUT / OUTPUT TERMINALS	26~28
12	OUTLINE DRAWING	29
13	QUALITY ASSURANCE	30
14	DESIGNATION OF LOT MARK	31
15	PACKAGE	32
16	PRECAUTIONS	33

1. SUMMARY

This technical specification applies to 5.7" color TFT-LCD panel with touch panel. The 5.7" color TFT-LCD panel is designed for industry, vehicle application and other electronic products which require high quality flat panel displays.

2. FEATURES

High Resolution: 230,400 Dots (320 RGB x 240). Image Reversion: Up/Down and Left/Right.

3. GENERAL SPECIFICATIONS

Parameter	Specifications	Unit	
Screen size	5.7(Diagonal)	inch	
Display Format	320 RGB x 240	Dot	
Active area	115.2(H) x 86.4(V)	mm	
Dot pitch	0.12(H) x 0.36(V)	mm	
Surface treatment	Anti-glare		
Pixel Configuration	RGB-Stripe		
Outline dimension	126.00(W) x 101.55(H) x 7.4(D)	mm	
Weight	(100)	g	
View Angle direction	6 o'clock		
Temperature Range	Operation	-20~70	°C
	Storage	-30~80	°C

4. ABSOLUTE MAXIMUM RATINGS

Item	Symbol	Condition	Min.	Max.	Unit	Remark
Power Voltage	V _{DD} ,V _{CC}	GND=0	-0.3	7.0	V	
	V _{GH}	GND=0	-0.3	32.0	V	
	V _{GL}	GND=0	-22.0	0.3	V	
	V _{GH} -V _{GL}	GND=0	-0.3	+45.0	V	
Input Signal Voltage	V _{in}	GND=0	-0.3	V _{DD} +0.3	V	
Logic Output Voltage	V _{OUT}	GND=0	-0.3	+0.7	V	

Note : Device is subject to be damaged permanently if stresses beyond those absolute maximum ratings listed above

5. ELECTRICAL CHARACTERISTICS

5.1. Operating conditions :

Parameter	Symbol	Rating			Unit	Condition
		Min.	Typ.	Max.		
Power Voltage	VCC	3.0	3.3	3.6	V	
	VDD	3.8	5	5.5	V	
	VGH	10	15	30	V	
	VGL	-17	-10	-5	V	
Low level input voltage	V_{IL}	0	-	0.3 VDD	V	SCL, SDI,UD,LRC,IF1,IF2
High level input voltage	V_{IH}	0.7 VDD	-	VDD	V	
Analog operating current	I_{VDD}	-	7	12	mA	$f_{CLKIN}=27MHz, f_{OEH}=15.7KHz, VDDA=5V$
Vcom High Voltage	VcomH	-	4.6	-	V	Note1
Vcom Low Voltage	VcomL		-0.4		V	Note1

Note :

1. VcomH& VcomL : Adjust the color with gamma data.

5.2 Power Sequence

Sequence for power on/off and Signal on/off

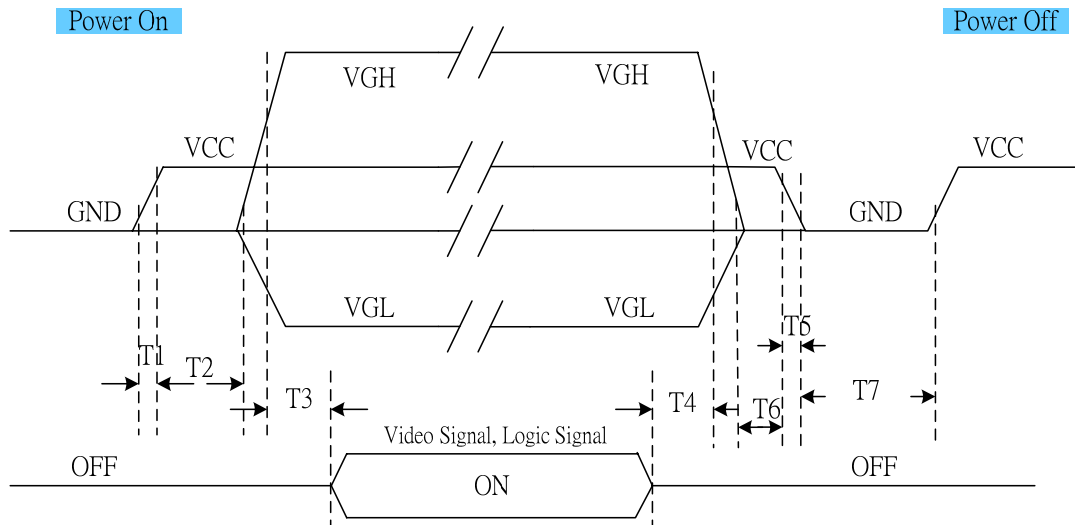

- T1 \leq 15ms (From 10%*VCC to 90%*VCC , when VCC is Low to High);
- T2 \leq 10ms (From 90%*VCC to 10%*VGH , when VCC is Low to High);
- T3 \leq 10ms (From 90%*VGH to Video signal , when VGH is Low to High);
- T4 \leq 10ms (From Video signal to 90%*VGH , when VGH is High to Low);
- T5 \leq 20ms (From 90%*VCC to 10%*VCC , when VCC is High to Low);
- T6 \leq 10ms (From 10%*VGH to 90%*VCC , when VCC is Low to High);
- T7 \geq 0.4s (From 10%*VCC is H \rightarrow L to 10%*VCC is L \rightarrow H) .

To prevent the device from damage due to latch-up, the power ON/OFF sequence shown below must be followed.

Power ON : VDD, VCC \rightarrow VGL \rightarrow Input Signals \rightarrow VGH

Power OFF : VGH \rightarrow Input Signals \rightarrow VGL \rightarrow VDD, VCC

5.3 LED driving conditions

Parameter	Symbol	Min.	Typ.	Max.	Unit	Remark
LED current	I_{LED}		140	210	mA	Note 1
LED voltage	V_{LED}	9.9	-	10.5	V	
LED Life Time	-	(20,000)	-	-	Hr	Note 2,3

Note 1 : There are 7 Groups LED (1 Group of three LEDs), $V_{LED1,2,3,4,5,6,7}=9.9$ V (min.)

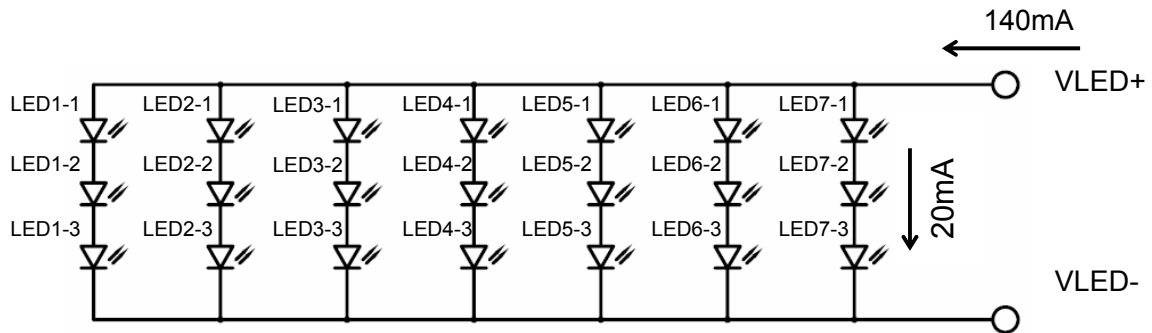

Note 2 : $T_a = 25^{\circ}C$,

Note 3 : Brightness to be decreased to 50% of the initial value

6. TOUCH PANEL

6.1 Block diagram

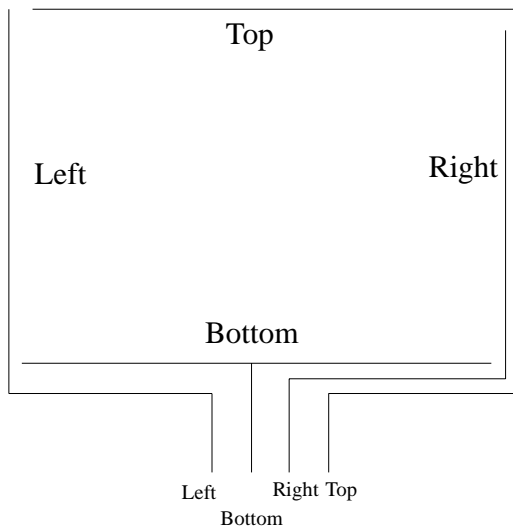

6.2 Absolute maximum ratings

Item	Symbol	Condictions	Specifications	Unit
Supply voltage	-	-	DC 5.0	V

6.3 Electrical characteristics

Item	Symbol	Condictions	Min	Typ	Max	Unit	Note
Resistance between terminal	Rx	-	200	460	900	ohm	Note1
	Ry	-	200	350	900	ohm	Note1
Insulation resistance	RINS	DC 25V	25	-	-	M ohm	Note1
Linearity (Note2,3)	-	-			1.5	%	Note1
Chattering	-	-			10max	ms	Note1

Note1.This specifications applied to only touch panel and calibration is more than 3 points.

Note 2.Test condition

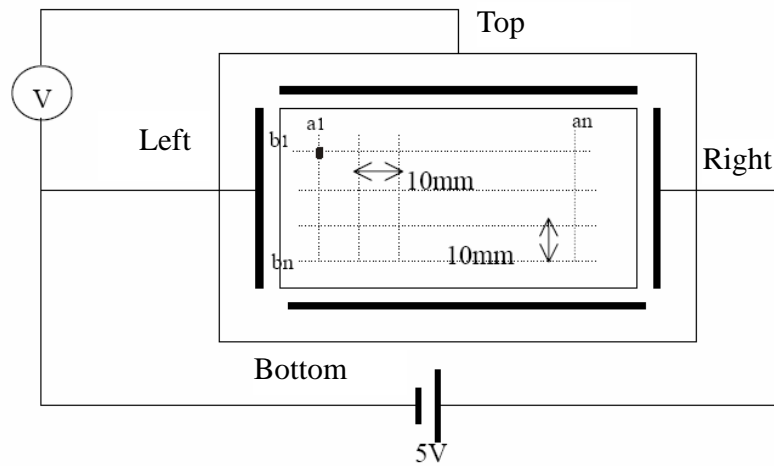

- (a) X- axis linearity method $V_{Y2}-V_{Y1}=5V$, $V_{OUT}=V_{X2}$
- (b) Y- axis linearity method $V_{X1}-V_{X2}=5V$, $V_{OUT}=V_{Y1}$

Note 3. Calculation

Define linearity X_i as:

$$\text{Linearity } X_i = \frac{|\Delta E_{\max}|}{(V_{an} - V_{a1})}$$

$$\text{Linearity } X = \text{Max}(\text{Linearity } x_1, \dots, \text{Linearity } x_n)$$

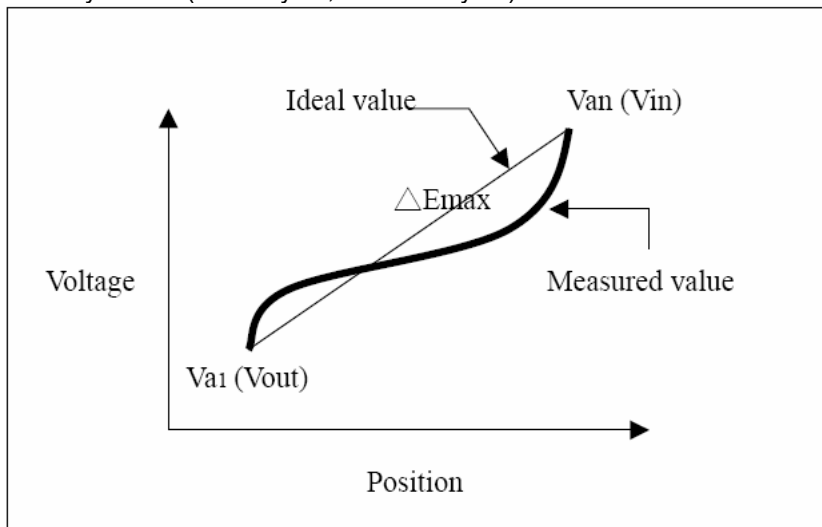

6.4 Mechanical characteristics

Item	Conditions	Specifications	Note
Operation force	pen (push vertically) (Top R0.8, material polyacetal)	80g max	
	rubber (push vertically) (Top R8, material polyacetal)	130g max	
Hardness of surface	3H(JIS-K5400)	Pencil hardness 2Hmin.	

7. AC Characteristics

7.1. CCIR601/656 Interface

7.1.1. Input signal characteristics

PARAMETER	Symbol	Min.	Typ.	Max.	Unit
CLK period	T_{OSC}	-	37	-	ns
Data setup time	T_{SU}	12	-	-	ns
Data hold time	T_{HD}	12	-	-	ns

7.1.2 Hardware reset timing

PARAMETER	Symbol	Min.	Typ.	Max.	Unit
RESET low pulse width	T_{RSB}	10	-	-	μs

7.1.3. Output signal characteristics

PARAMETER	Symbol	Min.	Typ.	Max.	Unit
Rising time	T_r	-	-	10	ns
Falling time	T_f	-	-	10	ns
Internal STH setup time	T_{SUS}	12	-	-	ns
Internal STH hold time	T_{HDS}	12	-	-	ns
Internal data setup time	T_{SUD}	60	-	-	ns
Internal data hold time	T_{HDD}	40	-	-	ns
OEH pulse width	T_{OEH}	-	1248	-	ns
OEV pulse width	T_{OEV}	-	4992	-	ns
CKV pulse width	T_{CKV}	-	3744	-	ns
Hsync – DEH time	T_1	-	4368	-	ns
Hsync – CKV time	T_2	-	2496	-	ns
Hsync – OEV time	T_3	-	624	-	ns
Vsync – setup time	T_{SUV}		1872	-	ns
Vsync – pulse time	T_{STV}		1	-	T_H
Vsync – STV time	NTSC		19	-	T_H
	PAL		27	-	T_H
OEH – STV time	T_{HE}	-	2	-	T_H
Output settling time	T_{OES}	-	12	20	μs

7.2. 24-bits parallel RGB Interface

7.2.1 AC Timing Characteristics

Signal	Item		Symbol	Min	Typ	Max	Unit
Dclk	Frequency		Dclk	-	6.4	-	MHZ
	High Time		Tch	-	78	-	ns
	Low Time		Tcl	-	78	-	ns
Data	Setup Time		Tds	12	-	-	ns
	Hold Time		Tdh	12	-	-	ns
Hsync	Period		TH	-	408	-	DCLK
	Pulse Width		Thp	-	30	-	DCLK
	Back-Porch		Thb	-	38	-	DCLK
	Display Period		Thd	-	320	-	DCLK
	Front-Porch		Thf	-	20	-	DCLK
Vsync	Period	NTSC	Tv	-	262.5	-	TH
		PAL			312.5		
	Pulse Width		Tvp	1	3	5	TH
	Back-Porch	NTSC	Tvb	-	15	-	TH
		PAL			23		
	Display Period		Tvd	-	240	-	TH
	Front-Porch	NTSC	Tvf	-	4.5	-	TH
		PAL			46.5		

7.2.2 AC Timing Diagrams

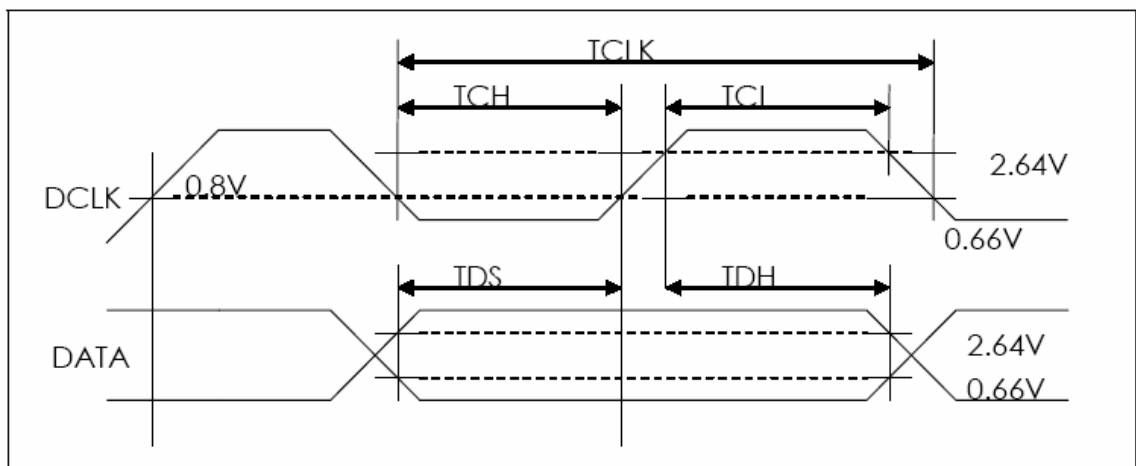
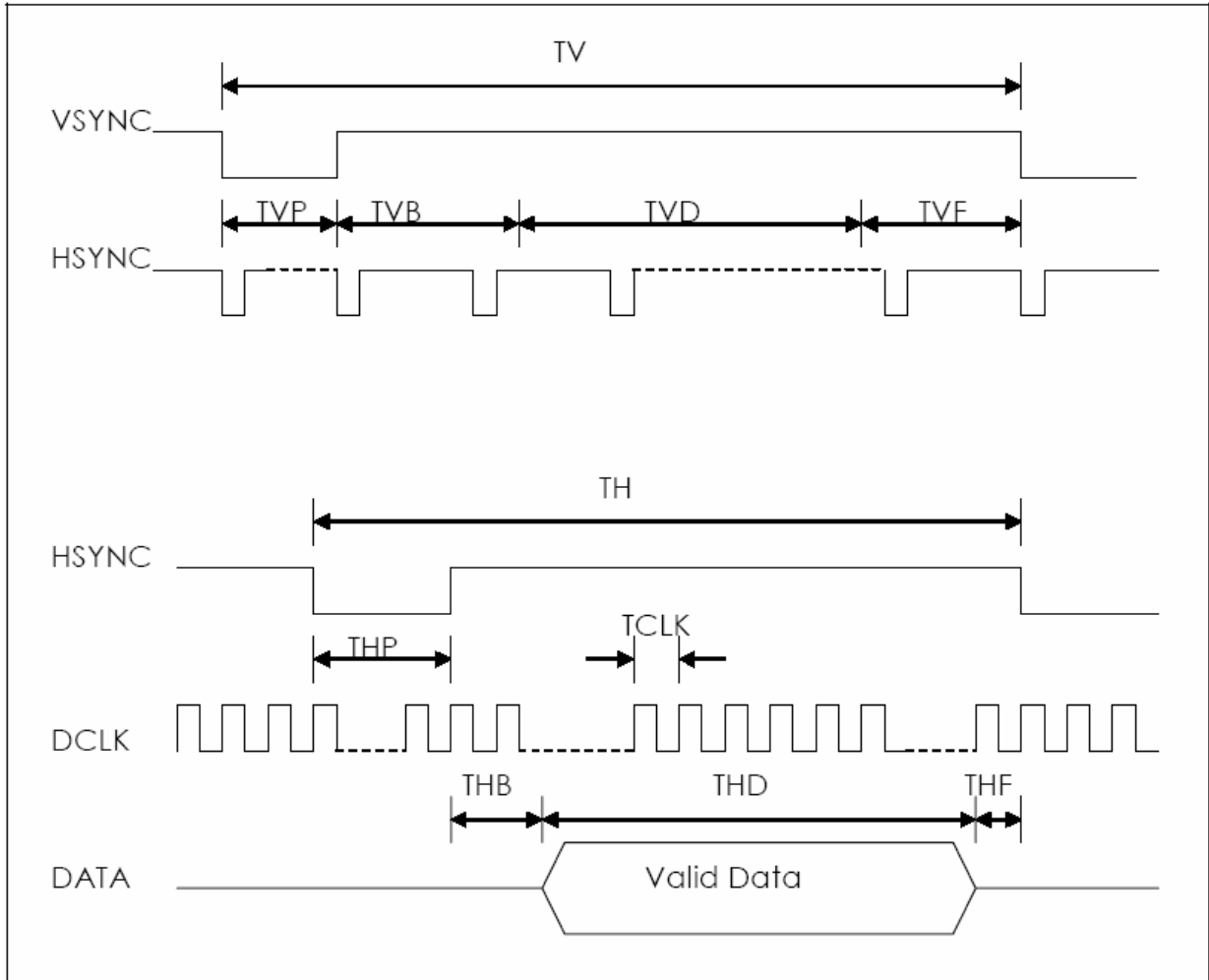

8. Waveform

8.1. Timing Controller Timing Chart

7.1.1. Clock and Data waveform

- CCIR601(HS_POL="L" in Register R2)

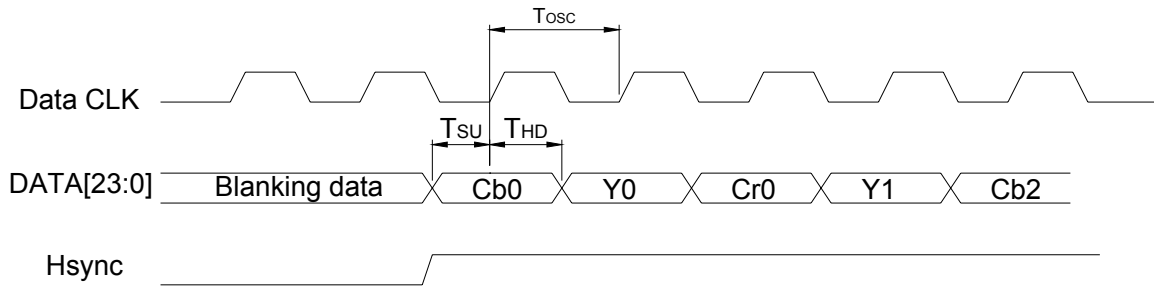

- CCIR656

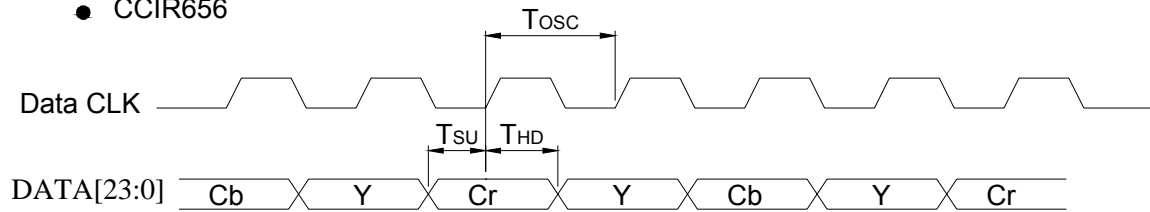

8.1.2 Digital / Analog RGB timing waveform

8.1.2.1 Hsync and Vsync timing

- Odd field

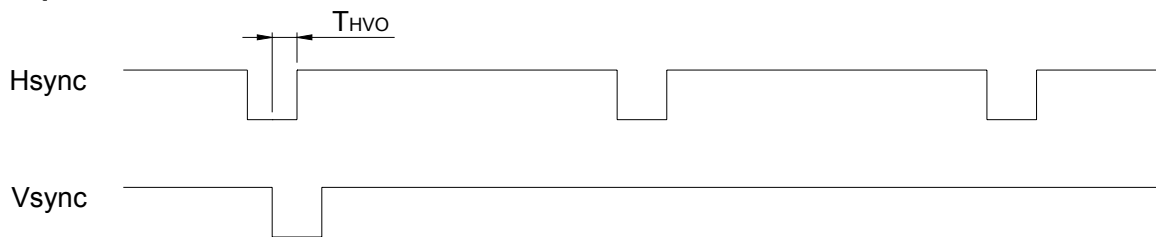

- Even field

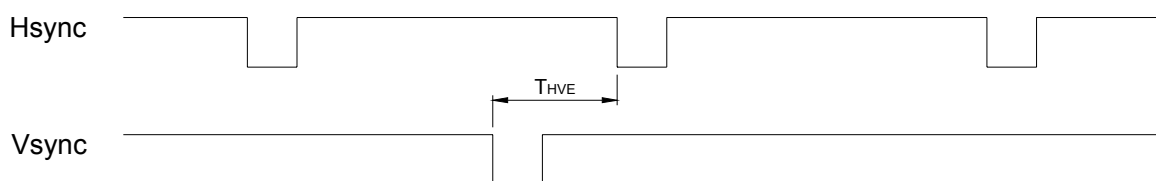

8.1.2.2 Hsync and horizontal control timing waveform

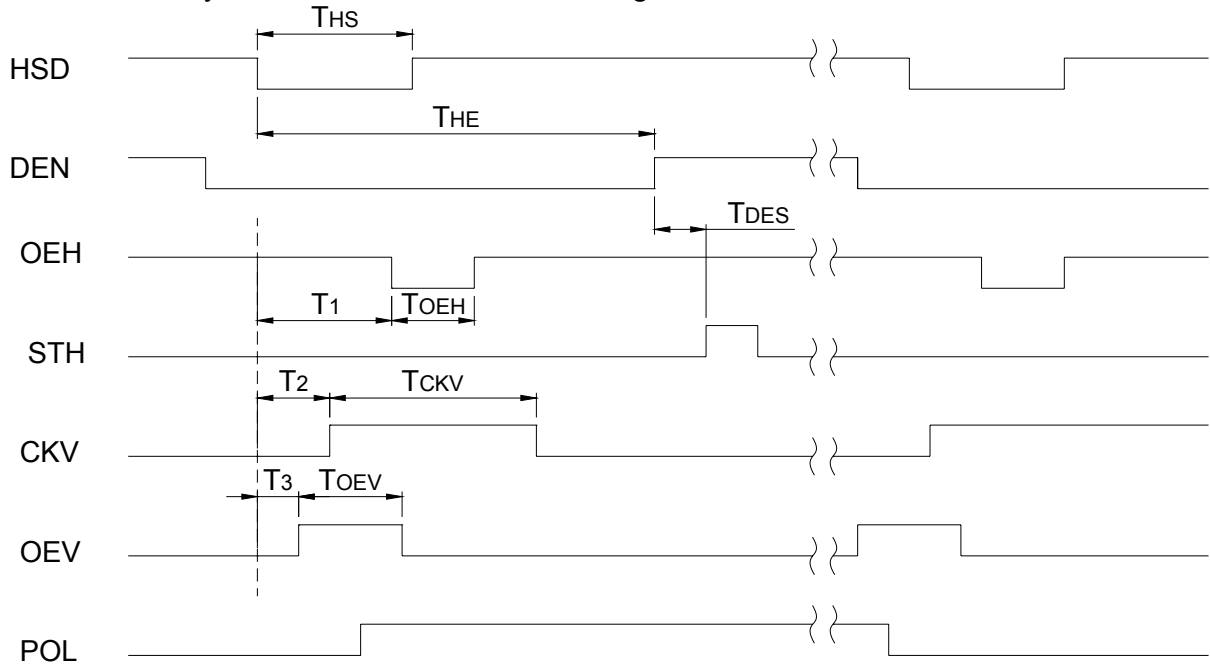

8.1.2.3 Hsync and vertical shift clock timing waveform

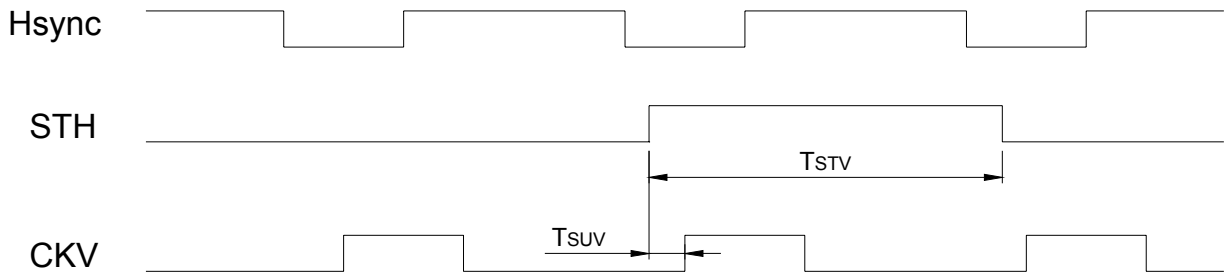

8.1.2.4 Hsync and vertical control timing waveform

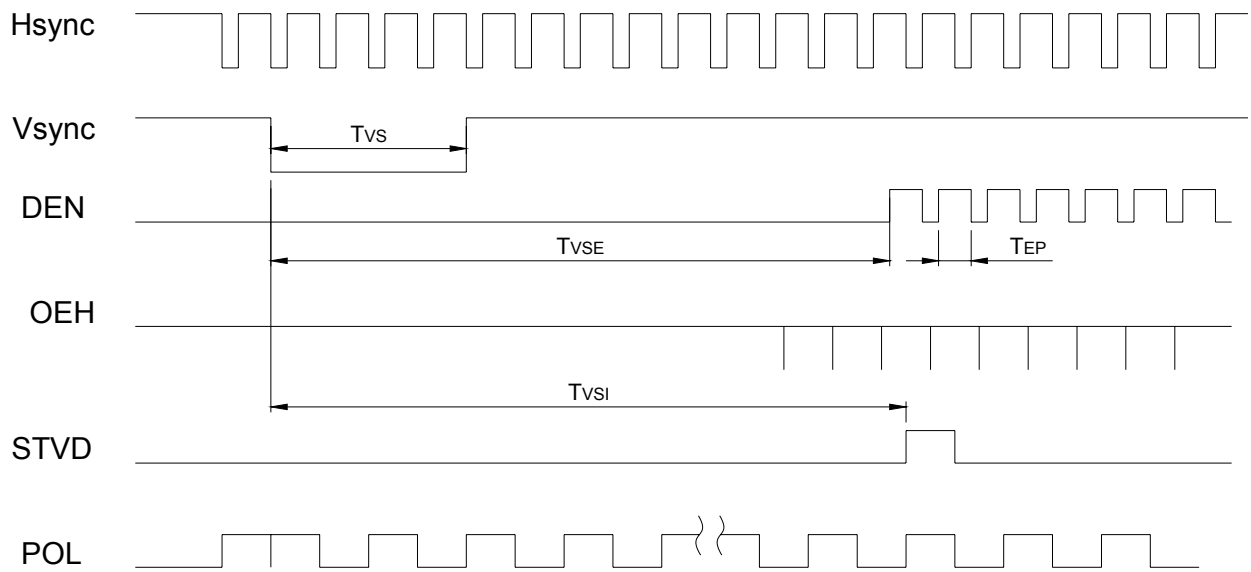

8.1.3 CCIR601 timing waveform (VS_POL="H" , HS_POL="L" in Register R2)

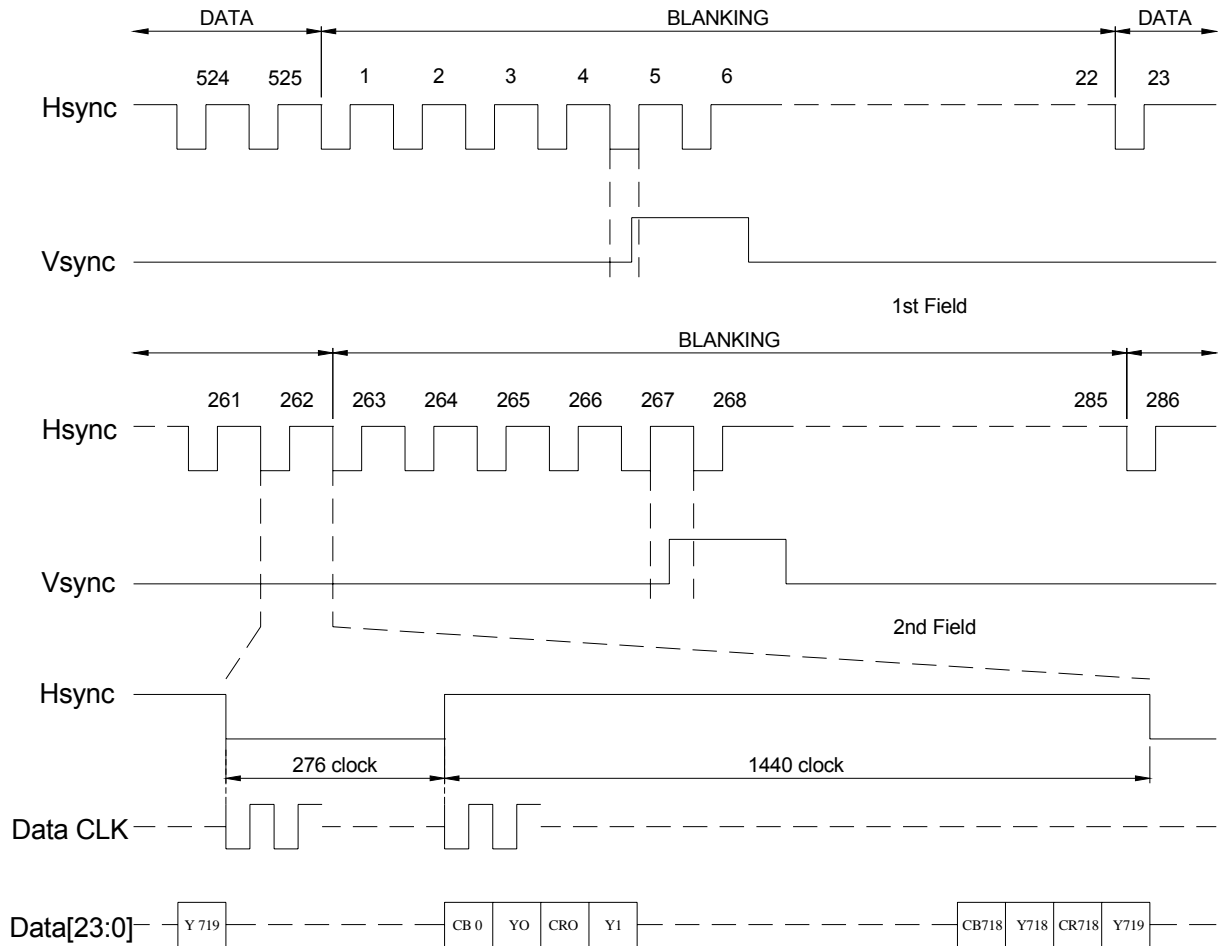

ITU-BT.601 NTSC Input Timing

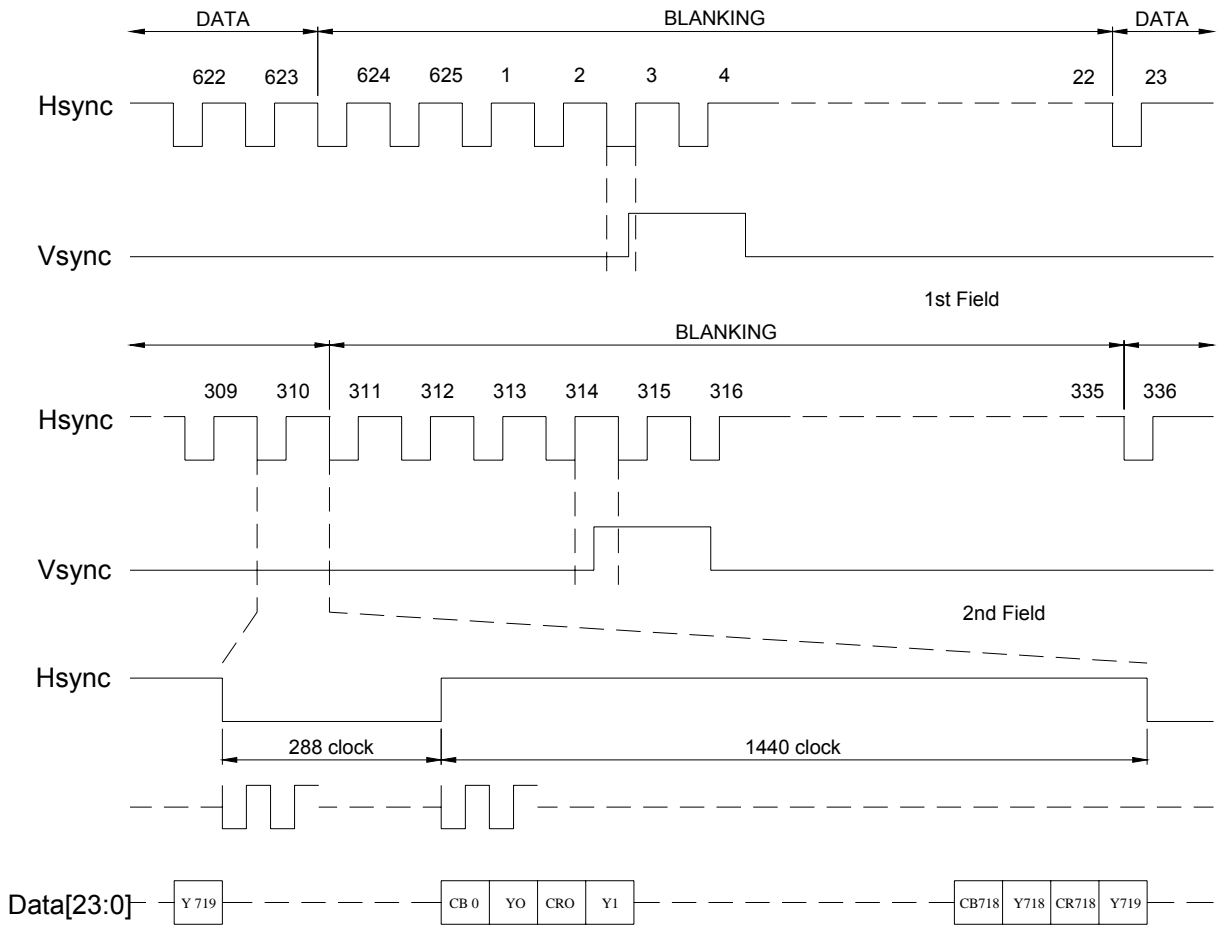

ITU-BT.601 PAL Input Timing

8.2 Source Driver Timing Chart

8.2.1 Clock and Start Pulse timing waveform

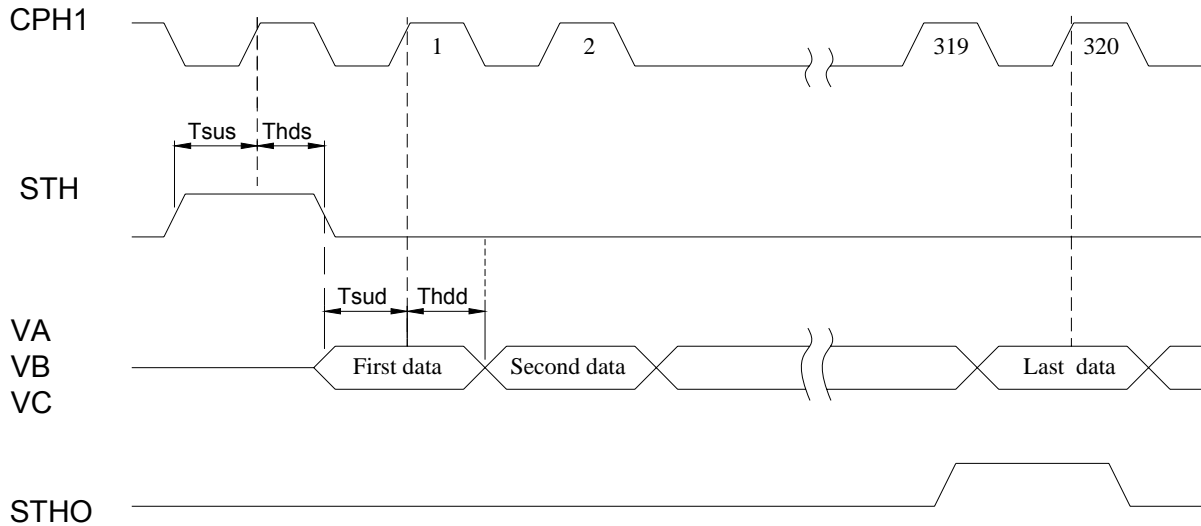

8.2.2 OEH and Data Output timing waveform

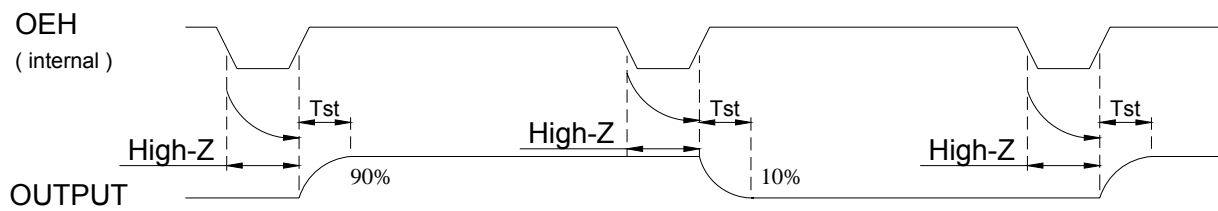

8.3 Analog video signal characteristics

PARAMETER	Symbol	Min.	Typ.	Max.	Unit
Video signal amplitude (VA, VB, VC)	V_{iAC}	-	3.81	-	V
	V_{iDC}	-	2.385	-	V

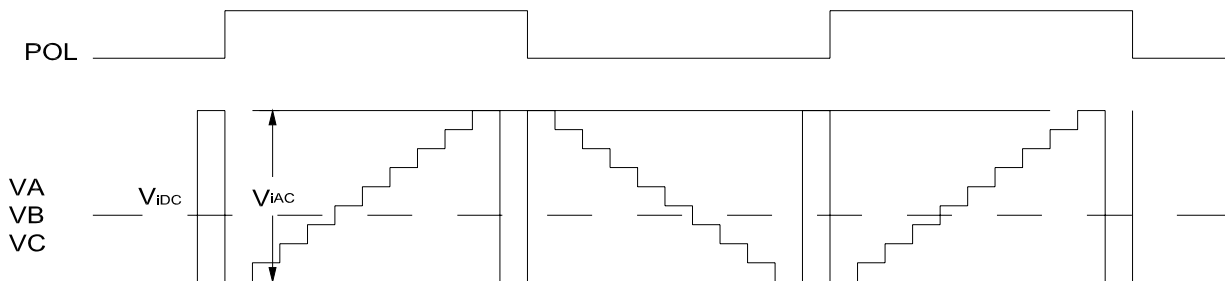
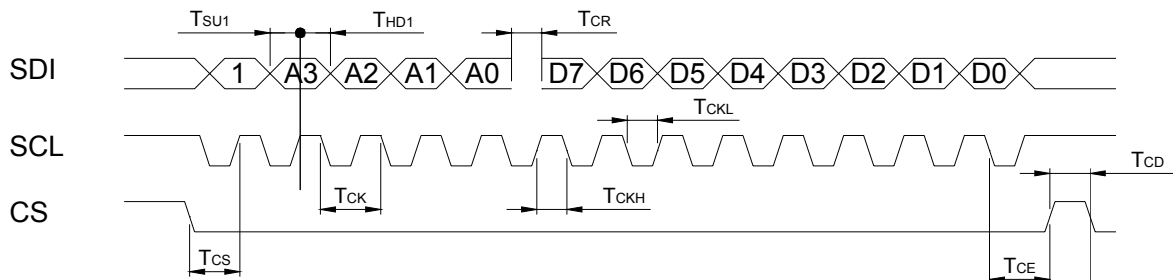

Fig. 4-(a) Horizontal timing

8.4 SPI timing characteristics

PARAMETER	Symbol	Min.	Typ.	Max.	Unit
SCL period	T_{CK}	60	-	-	ns
SCL high width	T_{CKH}	30	-	-	ns
SCL low width	T_{CKL}	30	-	-	ns
Data setup time	T_{SU1}	12	-	-	ns
Data hold time	T_{HD1}	12	-	-	ns
CS to SPCK setup time	T_{CS}	20	-	-	ns
CS to SPDA hold time	T_{CE}	20	-	-	ns
CS high pulse width	T_{CD}	50	-	-	ns
SDI output latency	T_{CR}		1/2	-	T_{CK}

● SPI "read" timing



● SPI "write" timing

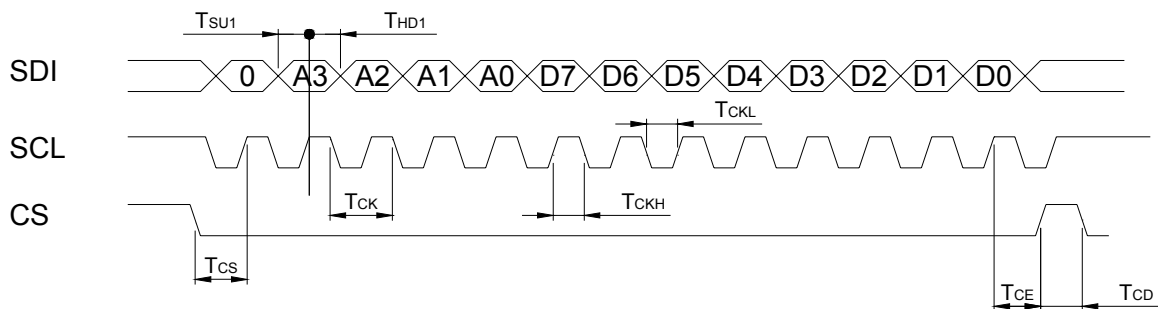

8.5 Gate Driver Timing Chart

Parameter	Symbol	Condition	Spec		Unit
			Min.	Max.	
Operation frequency	tCPV		5	-	μ s
CPV pulse width	tCPVH,tCPVL	50%duty cycle	2.5	-	
OE pulse width	twOE		1	-	
Data setup time	tsu		0.4	-	us
Data hold time	thd		0.7	-	
Output delay time	tpd1	CL=300pF	-	1	
Output delay time	tpd2	CL=300pF	-	0.8	
Output delay time	tpd3	CL=300pF	-	0.8	
Output delay time	tpd4	CL=300pF	-	10	

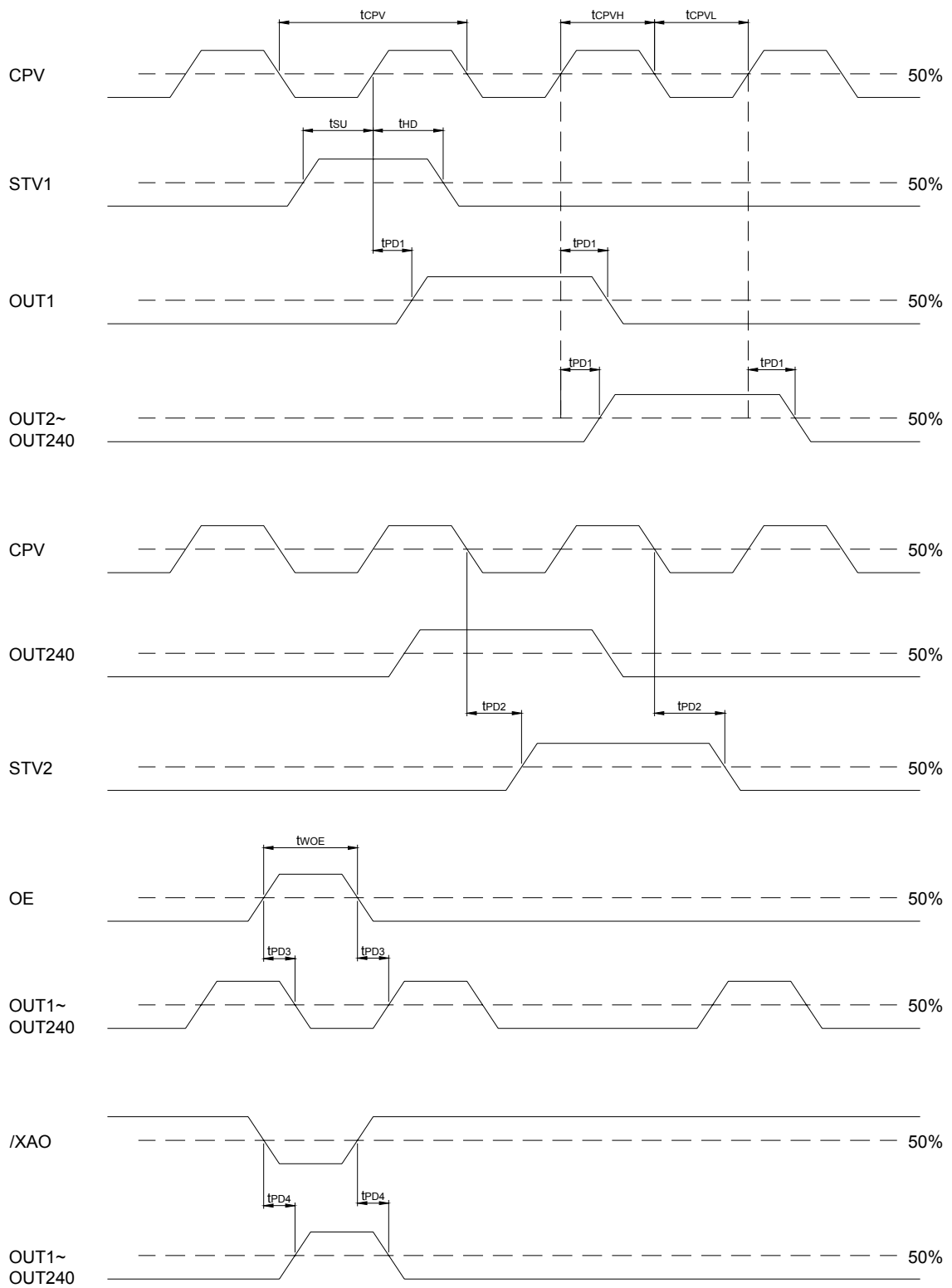

9. Optical Characteristics

$T_a=25\pm 2^\circ\text{C}$, ILED=20mA

Item	Symbol	Condition	Min.	Typ.	Max.	Unit	Remark	
Response time	Tr	$\theta=0^\circ$	-	15	30	ms	Note 3,5	
	Tf		-	35	50	ms		
Contrast ratio	CR	At optimized viewing angle	150	200			Note 4,5	
Color Chromaticity	White	Wx	(0.25)	(0.30)	(0.35)		Note 2,6,7	
		Wy	(0.27)	(0.32)	(0.37)			
Viewing angle	Hor.	θ_R	CR ≥ 10	50	65	-	Deg.	Note 1
		θ_L		50	65	-		
	Ver.	θ_T		30	50	-		
		θ_B		50	55	-		
Uniformity	U	-	(70)	(75)	-	%	Note 8	
Brightness	-	-		300	-	cd/m ²	Center of display	

Note 1: Definition of viewing angle range

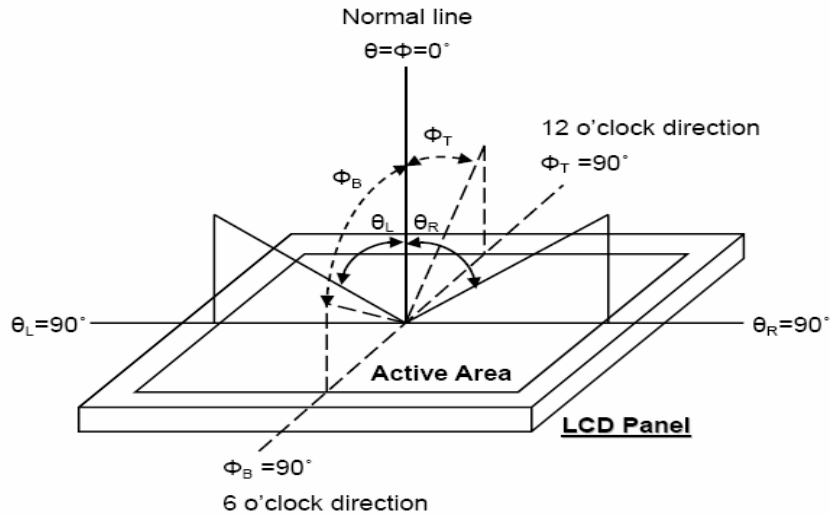

Fig. 8-1 Definition of viewing angle

Note 2: Test equipment setup:

After stabilizing and leaving the panel alone at a driven temperature for 10 minutes, the measurement should be executed. Measurement should be executed in a stable, windless, and dark room. Optical specifications are measured by Topcon BM-7 luminance meter 1.0° field of view at a distance of 50cm and normal direction.

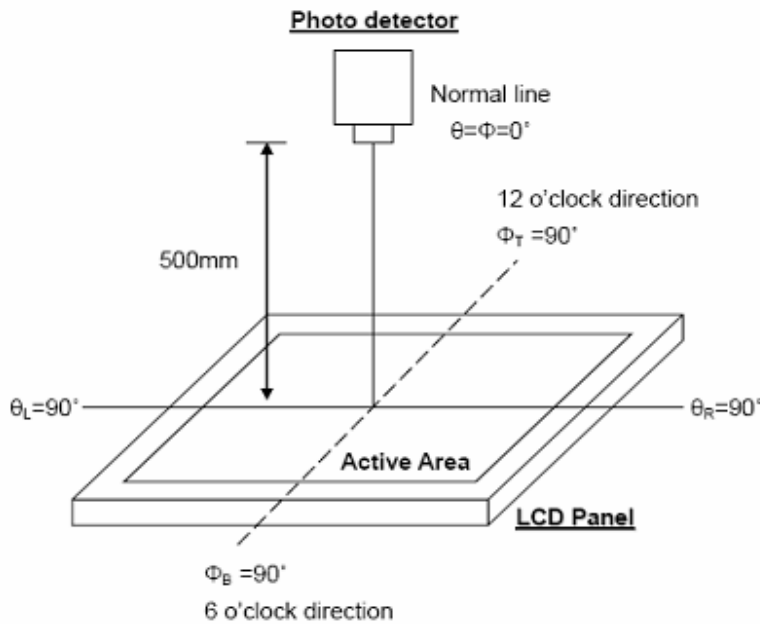

Fig. 8-2 Optical measurement system setup

Note 3: Definition of Response time:

The response time is defined as the LCD optical switching time interval between "White" state and "Black" state. Rise time, T_r , is the time between photo detector output intensity changed from 90% to 10%. And fall time, T_f , is the time between photo detector output intensity changed from 10% to 90%.

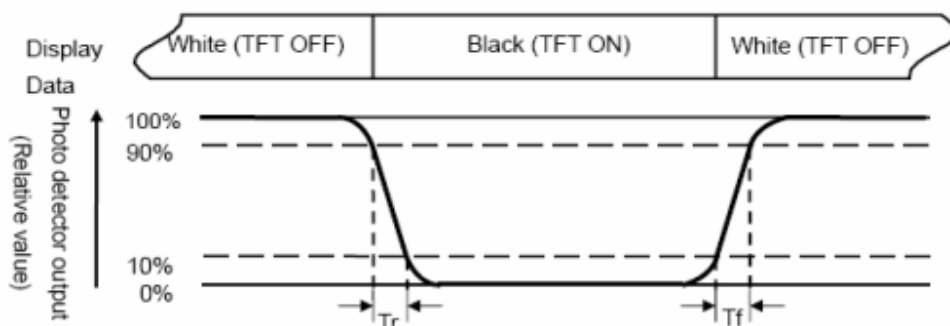

Fig. 3-3 Definition of response time

Note 4: Definition of contrast ratio:

The contrast ratio is defined as the following expression.

$$\text{Contrast ratio (CR)} = \frac{\text{Luminance measured when LCD on the "White" state}}{\text{Luminance measured when LCD on the "Black" state}}$$

Note 5: White $V_i = V_{i50} \pm 1.5V$

Black $V_i = V_{i50} \pm 2.0V$

“±” means that the analog input signal swings in phase with VCOM signal.

“±” means that the analog input signal swings out of phase with VCOM signal.

The 100% transmission is defined as the transmission of LCD panel when all the input terminals of module are electrically opened.

Note 6: Definition of color chromaticity (CIE 1931)

Color coordinates measured at the center point of LCD

Note 7: Measured at the center area of the panel when all the input terminals of LCD panel are electrically opened.

$$\text{Note 8 : Uniformity (U)} = \frac{\text{Brightness (min)}}{\text{Brightness (max)}} \times 100\%$$

10. BLOCK DIAGRAM

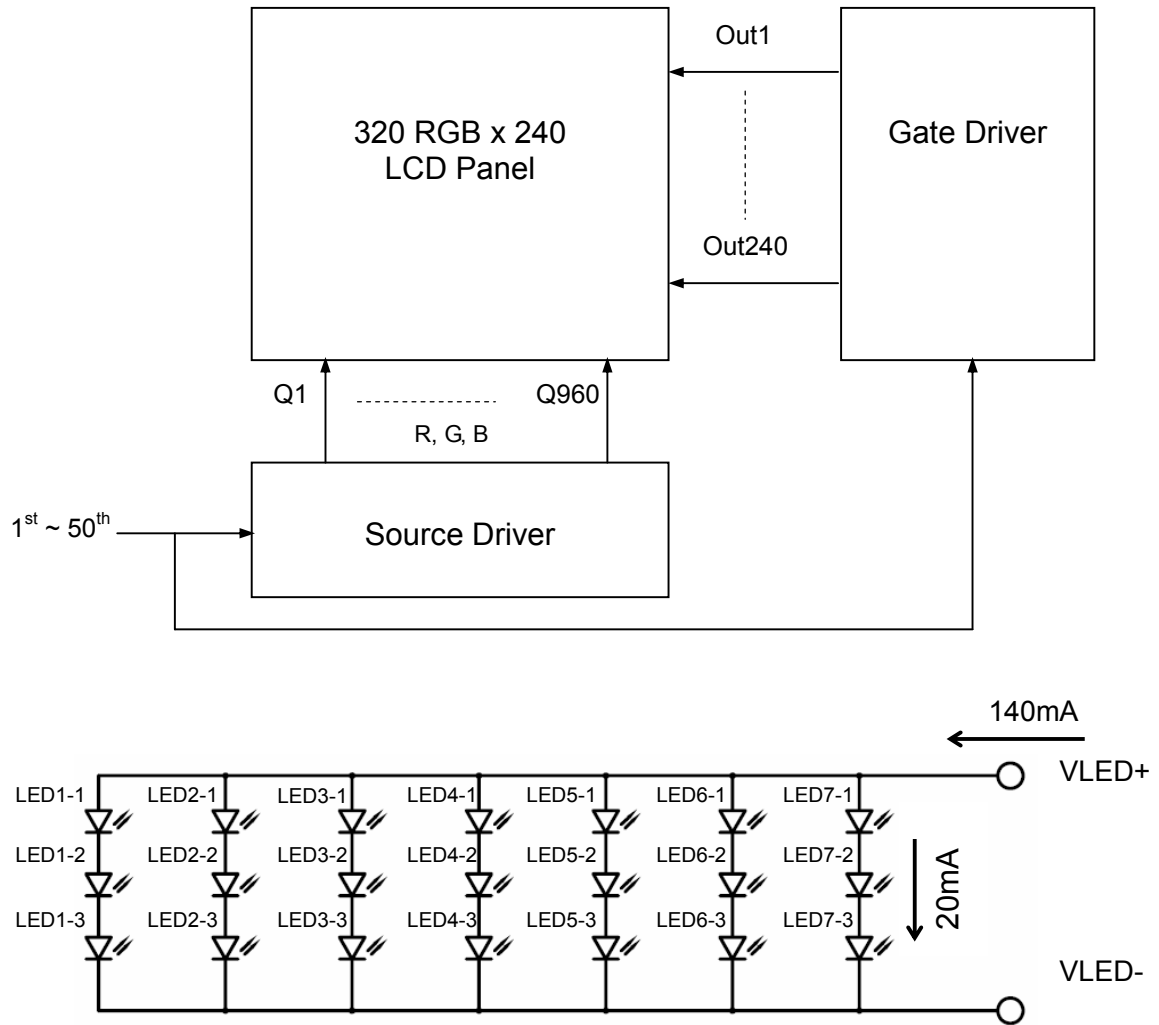

11. Input / Output Terminals

11.1. LCM PIN Definition

0.5mm Pitch FPC

Pin No.	Symbol	I/O	Description	Remark
1	DGND	I	GROUND	
2	+3.3V	I	Digital power: 3V~3.6V	
3	+3.3V	I	Digital power: 3V~3.6V	
4	DGND	I	GROUND	
5	VGL	I	Gate off power	
6	DGND	I	GROUND	
7	VGH	I	Gate on power	
8	DGND	I	GROUND	
9	UD	I	Up/Down scan setting. H: Reverse scan / L: Normal scan	
10	LR	I	The shift direction of device internal shift register is controlled by this pin as shown below: LRC=H: STH→Q1→.... →Q960→STHO LRC=L: STH→Q960→....→Q1→STHO	
11	SPENA	I	Chip select	Note1
12	SPCK	I	Serial Clock	Note1
13	SPDA	I/O	Serial Data	
14	POL	O	Polarity Signal connect to VCOM driving circuit.	Note2
15	DGND	I	GROUND	
16	B5	I	Blue Data bit (MSB)	
17	B4	I	Blue Data bit	
18	B3	I	Blue Data bit	
19	B2	I	Blue Data bit	
20	B1	I	Blue Data bit	
21	B0	I	Blue Data bit (LSB)	
22	TOP	I	Terminal Resistance	
23	RIGHT	I	Terminal Resistance	
24	DGND	I	GROUND	
25	G5	I	Green Data bit(MSB)	
26	G4	I	Green Data bit	
27	G3	I	Green Data bit	
28	G2	I	Green Data bit	
29	G1	I	Green Data bit	
30	G0	I	Green Data bit(LSB)	
31	BOTTOM	I	Terminal Resistance	
32	LEFT	I	Terminal Resistance	
33	AGND	I	Analog GROUND	
34	+5V	I	Analog power: 4.5V~5.5V	
35	+5V	I	Analog power: 4.5V~5.5V	
36	AGND	I	Analog GROUND	
37	R5	I	Red Data bit (MSB)	
38	R4	I	Red Data bit	
39	R3	I	Red Data bit	
40	R2	I	Red Data bit	
41	R1	I	Red Data bit	

42	R0	I	Red Data bit(LSB)	
43	DGND	I	GROUND	
44	DGND	I	GROUND	
45	DE	I	Data enable input.Normally pull low.	Note3
46	CLK	I	Dot data clock	
47	HS	I	Horizontal synchronous signal	
48	VS	I	Vertical synchronous signal	
49	VCOM	I	VCOM driving input	Note2
50	DGND	I	GROUND	

Note:

1. Pin 11 、 Pin 12 usually pull high.
2. The polarity of Vcom (Pin 49) should be generated from POL (Pin 14).
3. For digital RGB input data format, both SYNC mode and DE+SYNC mode are supported. If DE signal is fixed low, SYNC mode is used. Otherwise, DE+SYNC mode is used.
4. The phase of POL (pin 14):

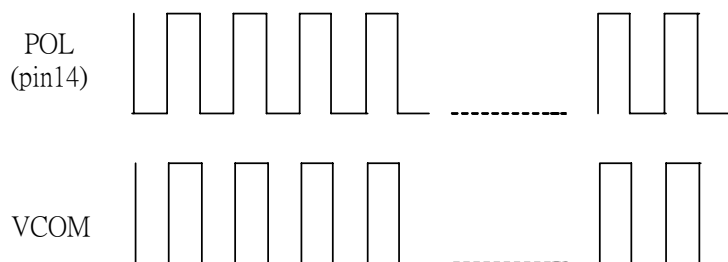

11.2. Backlight PIN Definition

Pin No.	Symbol	I/O	Description
1	LED +	I	Red, LED_ Anode (10Vdc, when ILED=140mA)
2	LED -	I	White, LED_ Cathode

Note: The backlight interface connector is a model **PHR-2** manufactured by JST or equivalent.
The matching connector part number is **S 2B-PH-K-S** manufactured by JST or equivalent.

11.3 Touch Panel Characteristics

11.3.1 Operation Force

Touch force 80g (with R8.0mm silicone finger)

11.3.2. Impact Resistance

No damage when φ 9mm steel ball is dropped on the surface from 75cm height

11.3.3. Static Load Resistance

After 45N load is applied on the area (25 cm²) of the touch panel after 30sec., still satisfy requirements in section 11.3.1.

11.3.4. Surface Hardness

3H or higher (with JIS K5600-5-4 standard)

11.3.5. Tail Peeling Resistance

0.5 kg/cm peeling upward by 90 degree

11.3.6. Tail Bending Resistance

Bending 10 times or more by bending radius R1.0mm 500g, each left and right side 135 degree

11.3.7. Tail Insert/Pull Out Resistance

20 times at least (for HSC/FPC connector)

11.3.8. Package Drop

Drop from 76 cm height to the ground, 6 faces, 1 corner and 3 ridges each time. After the test, no glass flaw, crack; no film scratch and no separate between film and glass.

11.4 Touch Panel Durability

11.4.1. Stylus Hitting

One million times or over
No damage on film surface

11.4.2 Touch Sliding Durability

100,000 times or over
Writing with R0.8mm plastic stylus pen; writing force 150g in active area.
Speed is 60mm/sec.

12. Outline Drawing

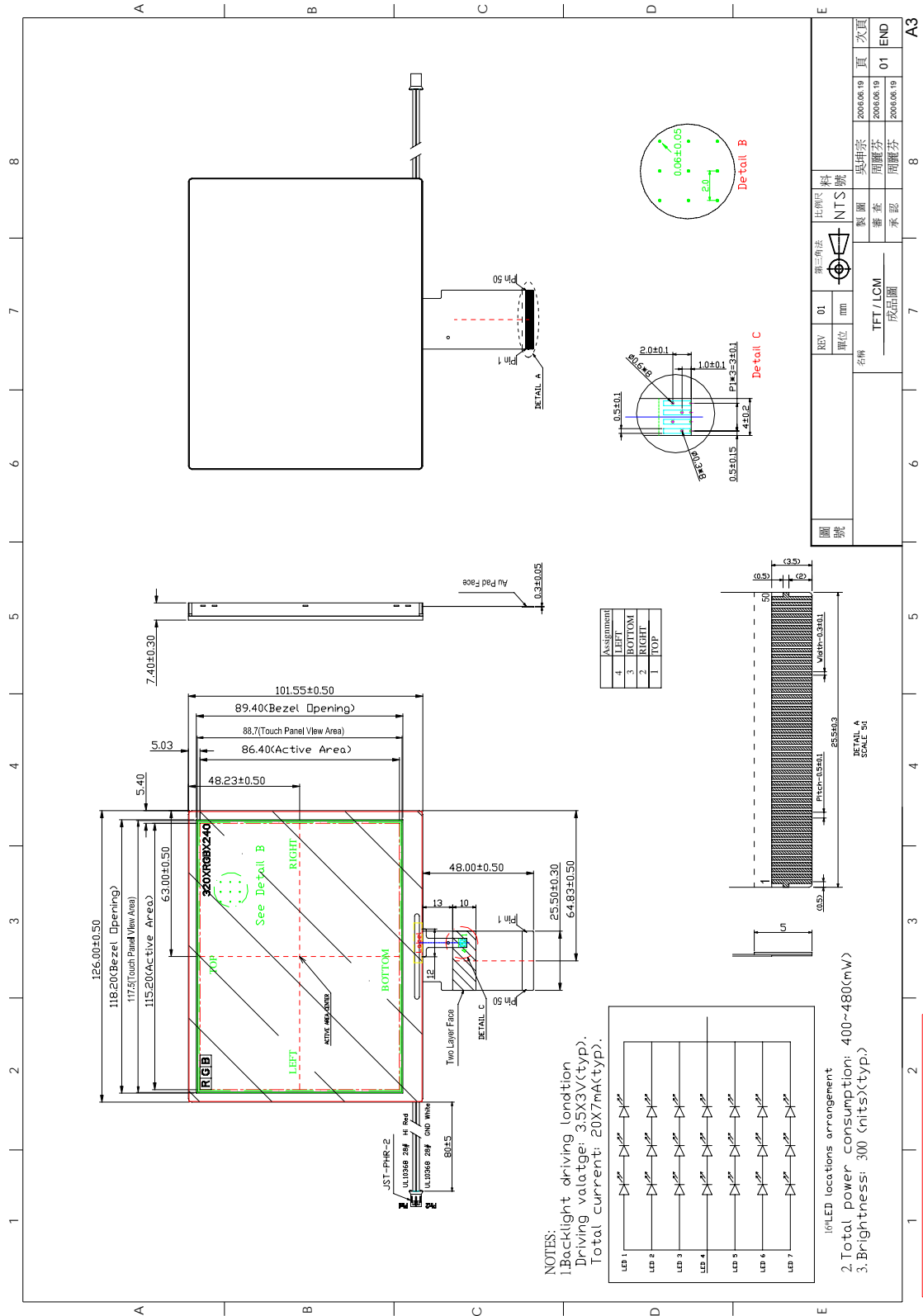

13. Quality Assurance

No.	Test Items	Test Condition	REMARK
1	High Temperature Storage Test	Ta=80°C 50%RH 240h	
2	Low Temperature Storage Test	Ta=-30°C Dry 240h	
3	High Temperature Operation Test	Ta=70°C 50%RH 240h	
4	Low Temperature Operation Test	Ta=-20°C Dry 240h	
5	High Temperature and High Humidity Operation Test	Ta=60°C 90%RH 240h	
6	Electro Static Discharge Test	-Panel Surface/Top_Case: 150pF ±15kV 150Ω (direct discharge, five times) -FPC input terminal : 100pF ±200V 0Ω	
7	Shock Test (non-operating)	Half sine wave, 180G, 2ms one shock of each six faces (I.e. run 180G 2ms for all six faces)	
8	Vibration Test (non-operating)	Sine wave, 10 ~ 500 ~ 10Hz, 1.5G, 0.37oct/min 3 axis, 1hour/axis	
9	Thermal Shock Test	-30°C(0.5h) ~ 80°C(0.5h) / 100 cycles	

***** Ta= Ambient Temperature

14. Designation Of Lot Mark

11-1. Lot Mark

a) Lot Mark

A	B	C	D	E	F	G	H	I	J	K	L
---	---	---	---	---	---	---	---	---	---	---	---

A : YEAR

B,C : MONTH

D : WEEK

E,F : PRODUCTION MANAGEMENT

G,H,I,J,K : SERIAL NO.

Note

1. YEAR

Year	2003	2004	2005	2006	2007	2008	2009	2010	2011	2012
Mark	3	4	5	6	7	8	9	0	1	2

2. MONTH

Month	Jan	Fed	Mar	Apr	May	Jun	Jul	Aug	Sep	Oct	Nov	Dec
Mark	01	02	03	04	05	06	07	08	09	10	11	12

3. WEEK

Week	1st~7th	8th~14th	15th~21st	22nd~28th	29th~31st
Mark	1	2	3	4	5

4. SERIAL NO.

Year	1~999999	1000000~
Mark	000001~999999	A00000~A99999,,Z99999

b) Location of Lot Mark

Serial NO. is printed on the label. The label is attached to the backside of the LCD module. This is subject to change without prior notice.

15 . Packing Form

a. Inner package

(1) Quantity : 40pcs / 1Box

(2) Size : (L)510x(W)310x(H)269

(unit : mm)

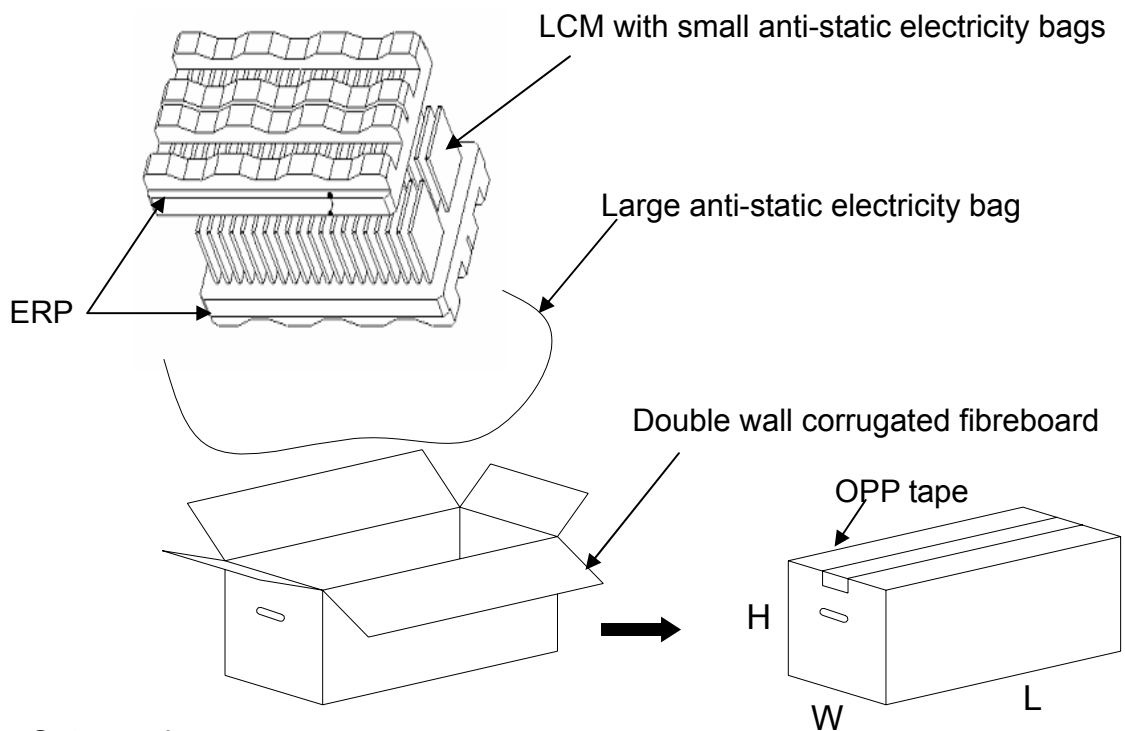

b. Outer package

(1) Quantity : 720pcs / 1Box

(2) Size : (L)1100x(W)1000x(H)950

(unit : mm)

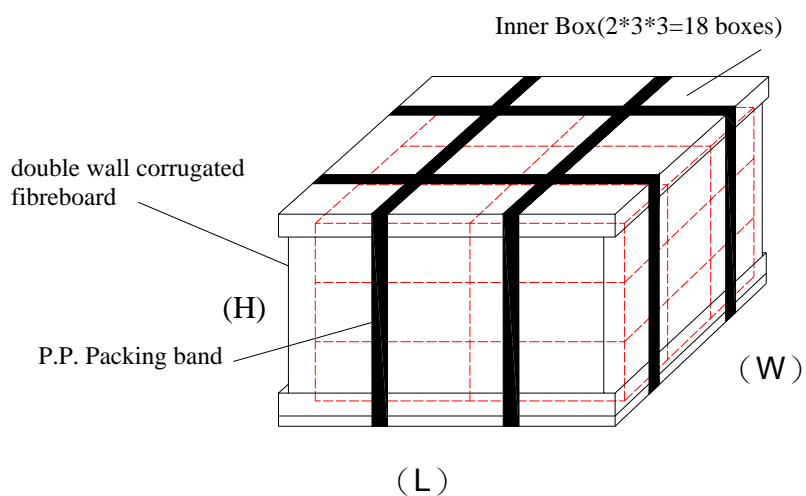

16 . PRECAUTIONS

Please pay attention to the following when you use this TFT LCD module.

16-1.MOUNTING PRECAUTIONS

- (1) You must mount a module using arranged in four corners or four sides.
- (2) You should consider the mounting structure so that uneven force (ex. Twisted stress) is not applied to the module.
And the case on which a module is mounted should have sufficient strength so that external force is not transmitted directly to the module.
- (3) Please attach a transparent protective plate to the surface in order to protect the polarizer. Transparent protective plate should have sufficient strength in order to the resist external force.
- (4) You should adopt radiation structure to satisfy the temperature specification.
- (5) Acetic acid type and chlorine type materials for the cover case are not describe because the former generates corrosive gas of attacking the polarizer at high temperature and the latter causes circuit break by electro-chemical reaction.
- (6) Do not touch, push or rub the exposed polarizers with glass, tweezers or anything harder than HB pencil lead. And please do not rub with dust clothes with chemical treatment. Do not touch the surface of polarizer for bare hand or greasy cloth. (Some cosmetics are determined to the polarizer)
- (7) When the surface becomes dusty, please wipe gently with adsorbent cotton or other soft materials like chamois soaks with petroleum benzene. Normal-hexane is recommended for cleaning the adhesives used to attach front / rear polarizers. Do not use acetone, toluene and alcohol because they cause chemical damage to the polarizer.
- (8) Wipe off saliva or water drops as soon as possible. Their long time contact with polarizer causes deformations and color fading.
- (9) Do not open the case because inside circuits do not have sufficient strength.

16-2. OPERATING PRECAUTIONS

- (1) The spike noise causes the mis-operation of circuits. It should be lower than following voltage : $V=\pm 200\text{mV}$ (Over and under shoot voltage)
- (2) Response time depends on the temperature. (In lower temperature, it becomes longer.)
- (3) Brightness depends on the temperature. (In lower temperature, it becomes lower)
And in lower temperature, response time (required time that brightness is stable after turned on) becomes longer.
- (4) Be careful for condensation at sudden temperature change. Condensation makes damage to polarizer or electrical contacted parts. And after fading condensation, smear or spot will occur.
- (5) When fixed patterns are displayed for a long time, remnant image is likely to occur.
- (6) Module has high frequency circuits. Sufficient suppression to the electromagnetic interference shall be done by system manufacturers. Grounding and shielding methods may be important to minimize the interference.

16-3 ELECTROSTATIC DISCHARGE CONTROL

Since a module is composed of electronic circuits, it is not strong to electrostatic discharge. Make certain that treatment persons are connected to ground through wristband etc. And don't touch interface pin directly.

16-4 PRECAUTIONS FOR STRONG LIGHT EXPOSURE

Strong light exposure causes degradation of polarizer and color filter.

16-5 STORAGE

When storing modules as spares for a long time, the following precautions are necessary.

- (1) Store them in a dark place. Do not expose the module to sunlight or fluorescent light. Keep the temperature between 5°C and 35°C at normal humidity.
- (2) The polarizer surface should not come in contact with any other object. It is recommended that they be stored in the container in which they were shipped.

16-6 HANDLING PRECAUTIONS FOR PROTECTION FILM

- (1) When the protection film is peeled off, static electricity is generated between the film and polarizer. This should be peeled off slowly and carefully by people who are electrically grounded and with well ion-blown equipment or in such a condition, etc.
- (2) The protection film is attached to the polarizer with a small amount of glue. Is apt to remain on the polarizer.
Please carefully peel off the protection film without rubbing it against the polarizer.
- (3) When the module with protection film attached is stored for a long time, sometimes there remains a very small amount of glue still on the polarizer after the protection film is peeled off.
- (4) You can remove the glue easily. When the glue remains on the polarizer surface or its vestige is recognized, please wipe them off with absorbent cotton waste or other soft material like chamois soaked with normal-hexane.

16-7 Cautions for installing and assembling

Bezel edge must be positioned in the area between the Active area and View area. The bezel may press the touch screen and cause activation if the edge touches the active area. A gap of approximately 0.5mm is needed between the bezel and the top electrode. It may cause unexpected activation if the gap is too narrow. There is a tolerance of 0.2 to 0.3mm for the outside dimensions of the touch panel and tail. A gap must be made to absorb the tolerance in the case and connector.

