



# LCD MODULE SPECIFICATION

**Customer:** \_\_\_\_\_  
**Model Name:** OSD056TN52  
**SPEC NO.:** A056-52-TT-01  
**Date:** 2006/12/20  
**Version:** 01

- Preliminary Specification(Tentative)  
 Final Specification

For Customer's Acceptance

Approved by	Comment

Approved by	Reviewed by	Prepared by



## Record of Revision

Version	Revise Date	Page	Content
Pre-spec.01	2006/12/20		Pre-specification.

## Contents:

1.General Specifications .....	1
2.Pin Assignment .....	2
3.Operation Specifications .....	4
3.1.Absolute Maximum Rating .....	4
3.1.1.Typical Operation Conditions.....	5
3.1.2.Current Consumption .....	6
3.1.3. Backlight Driving Conditions.....	6
3.2.Power Sequence .....	7
3.3.Timing Characteristics .....	8
3.3.1.Timing Conditions.....	8
3.3.2.Timing Diagram .....	10
4. Optical Specifications .....	13
5.Reliability Test .....	17
6.General Precautions .....	18
6.1.Safety .....	18
6.2.Handling .....	18
6.3.Static Electricity.....	18
6.4.Storage .....	18
6.5.Cleaning .....	18
7.Mechanical Drawing.....	19
8.Package Drawing.....	20

# 1.General Specifications

No.	Item	Specification	Remark
1	LCD size	5.6 inch(Diagonal)	
2	Driver element	a-Si TFT active matrix	
3	Resolution	640X(RGB)X480	
4	Display mode	Normally White, Transmissive	
5	Dot pitch	0.0588(W)X0.1764(H) mm	
6	Active area	112.896 (W)X84.672(H) mm	
7	Module size	126.5(W)X100(H)X6.8(D) mm	Note 1
8	Surface treatment	Anti-Glare	
9	Color arrangement	RGB-stripe	
10	Interface	Digital	
11	Backlight Power consumption	TBD	
12	Panel Power consumption	TBD	
13	Weight	TBD	

Note 1: Refer to Mechanical Drawing.

## 2.Pin Assignment

### TFT LCD Panel Driving Section

Note: FPC connector is used for the module electronics interface. The recommended model is FH19S-40S-0.5SH manufactured by HiRose.

Pin No.	Symbol	I/O	Function	Remark
1	VLED	P	Voltage for LED circuit	
2	VLED	P	Voltage for LED circuit	
3	ADJ	I	Adjust the led brightness	
4	GLED	P	Ground for LED circuit	
5	GLED	P	Ground for LED circuit	
6	VCC	P	Power supply for digital circuit	
7	VCC	P	Power supply for digital circuit	
8	MODE	I	DE or HV mode control	
9	DE	I	Data enable	
10	VS	I	Vsync signal input	
11	HS	I	Hsync signal input	
12	GND	P	Power ground	
13	B5	I	Blue data input (MSB)	
14	B4	I	Blue data input	
15	B3	I	Blue data input	
16	GND	P	Power ground	
17	B2	I	Blue data input	
18	B1	I	Blue data input	
19	B0	I	Blue data input(LSB)	
20	GND	P	Power ground	
21	G5	I	Green data input(MSB)	
22	G4	I	Green data input	
23	G3	I	Green data input	
24	GND	P	Power ground	
25	G2	I	Green data input	

26	G1	I	Green data input	
27	G0	I	Green data input(LSB)	
28	GND	P	Power ground	
29	R5	I	Red data input(MSB)	
30	R4	I	Red data input	
31	R3	I	Red data input	
32	GND	P	Power ground	
33	R2	I	Red data input	
34	R1	I	Red data input	
35	R0	I	Red data input(LSB)	
36	GND	P	Power ground	
37	DCLK	I	Sample clock	
38	GND	P	Power ground	
39	L/R	I	Select left to right scanning direction	
40	U/D	I	Select up or down scanning direction	

Note: I: input, O: output t, P: Power

### 3.Operation Specifications

#### 3.1.Absolute Maximum Rating

(Note 1)

Item	Symbol	Values		Unit	Remark
		Min.	Max.		
Power voltage	V <sub>LED</sub>	4.5	5.5	V	
	V <sub>DD</sub>	(-0.3)	(7)	V	
Operation temperature	T <sub>OP</sub>	-20	70	°C	Note 3
Storage temperature	T <sub>ST</sub>	-30	80	°C	Note 3 Note 4
LED Forward Voltage	V <sub>r</sub>	3.1	3.5	V	Each LED Note 2
LED Forward Current	I <sub>f</sub>	-	25	mA	Each LED

Note 1: The absolute maximum rating values of the module should not be exceeded. Once exceeded absolute maximum rating values, the characteristics of the module may not be recovered. Even in an extreme condition, may result in module permanently destroyed.

Note 2: V<sub>r</sub> Conditions: Zener Diode 20mA

Note 3: 90% RH Max.(Max wet temp. is 40°C )Maximum wet-bulb temperature is at 38°C or less. And No condensation (no drops of dew)

Note 4: In case of below 0°C the response time of liquid crystal (LC) becomes slower and the color of panel darker than normal one.  
Level of retardation depends on temperature because of LC's characteristics.

### 3.1.1. Typical Operation Conditions

Item	Symbol	Values			Unit	Remark
		Min.	Typ.	Max.		
Power voltage	$V_{DD}$	3.1	3.3	3.5	V	
	$V_{LED}$	4.8	5.0	5.2	V	
Input logic high voltage	$V_{IH}$	$0.7V_{DD}$	-	$1V_{DD}$	V	Note 1
Input logic low voltage	$V_{IL}$	0	-	$0.3V_{DD}$	V	

Note 1: R0~R5,G0~G5,B0~B5,HSYNC,VSYNC,DE,SPENA,SPCK,SPDA.

### 3.1.2. Current Consumption

Item	Symbol	Values			Unit	Remark
		Min.	Typ.	Max.		
Current for Driver	$I_{DD}$	-	TBD	TBD	mA	$V_{DD} = 3.3V$
Current for Backlight	$I_{LED}$	-	TBD	TBD	mA	$V_{LED} = 5.0V$

### 3.1.3. Backlight Driving Conditions

Item	Symbol	Values			Unit	Remark
		Min.	Typ.	Max.		
LED forward voltage	$V_L$	-	TBD		V	Note 2,3
LED forward current	$I_L$	-	20		mA	Note 3
LED life time	-	20,000	-	-	Hr	Note 1

Note 1: The “LED life time” is defined as the module brightness decrease to 50% original brightness at  $T_a = 25^\circ C$  and  $I_L = 20mA$ . The LED lifetime could be decreased if operating  $I_L$  is larger than 20 mA.

Note 2: The LED Supply Voltage is defined by the number of LED at  $T_a = 25^\circ C$  and  $I_L = 20mA$ .

Note 3: The LED driving condition is defined for each LED module.( 3 LED Serial)

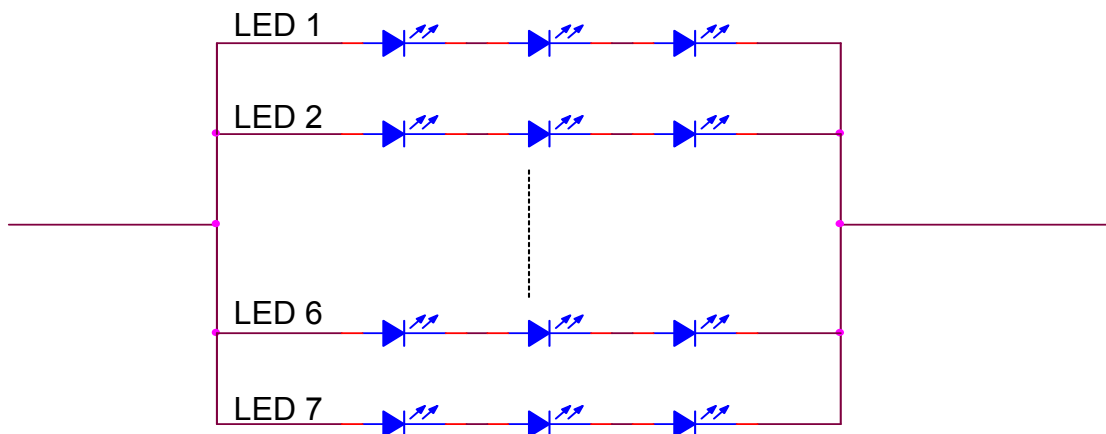

### 3.2.Power Sequence

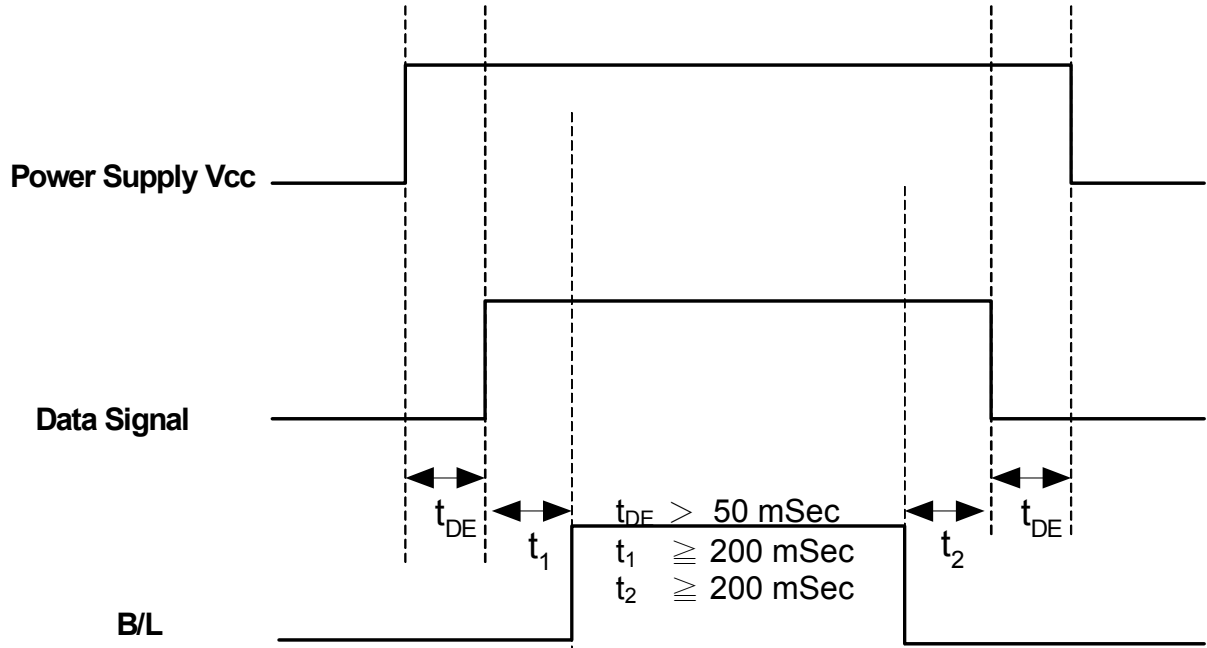

### 3.3.Timing Characteristics

#### 3.3.1.Timing Conditions

Input/Output Timing

Item	Symbol	Values			Unit.	Remark
		Min.	Typ.	Max.		
PXLCLK clock time	Tclk	-		37	ns	
PXLCLK pulse duty	Tcwh	40	50	60	%	Tclk
DATA set-up time	Tdsu	12	-	-	ns	DATA to PXLCLK
DATA hold time	Tdhd	12	-	-	ns	DATA to PXLCLK
DE setup time	Tesu	12	-	-	ns	DE to PXLCLK
VSYNC setup time	Tvst	12	-	-	ns	
VSYNC hold time	Tvhd	12	-	-	ns	
HSYNC setup time	Thst	12	-	-	ns	
HSYNC hold time	Thhd	12	-	-	ns	
HSYNC period time	Th	60	63.56	67	us	
HSYNC width	Thwh	1	-	-	Tclk	
VSYNC width	Tvwh	1	-	-	Th	
HSYNC to CLKIN	Thc	-	-	1	Tclk	

DE Mode input Timing Limitation

DE Mode	Values			Unit	Remark
	Min.	Typ.	Max.		
TCLK	33.3	39.7	--	ns	1tclk
THC	40	160	765	tclk	
THD	640	640	640	tclk	
TH	680	800	1405	tclk	1TH=1line
TVC	6	45	255	line	
TVD	480	480	480	line	
TV	486	525	735	line	1TV=1field

HV Mode input Timing Limitation

HV Mode	Values			Unit	Remark
	Min.	Typ.	Max.		
Tclk	33.3	39.7	--	ns	1tclk
Thwh	1	10	255	tclk	
Thbp	40	70	255	tclk	With 3-wire
Thbp	70	70	70	tclk	Without 3-wire
Thfp	8	90	255	tclk	
THD	640	640	640	tclk	
TH	688	800	1405	tclk	With 3-wire
Tvwh	1	2	255	line	
Tvbp	6	13	128	line	With 3-wire
Tvbp	13	13	13	line	Without 3-wire
Tvfp	4	32	255	line	
TVD	480	480	480	line	
TV	490	525	735	line	1TV=1field

### 3.3.2. Timing Diagram

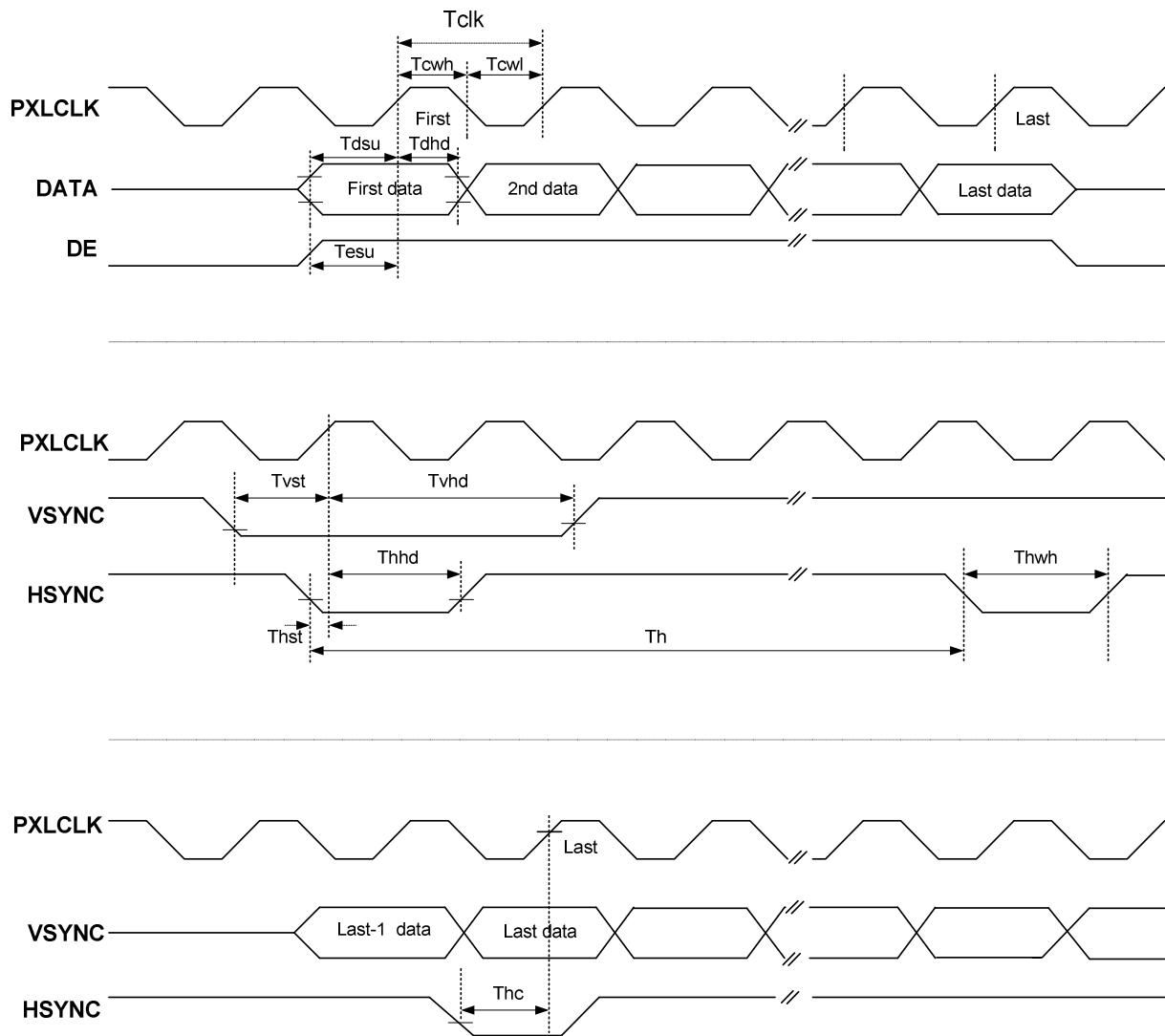

Fig.3-1 Clock and Data Input Timing Diagram

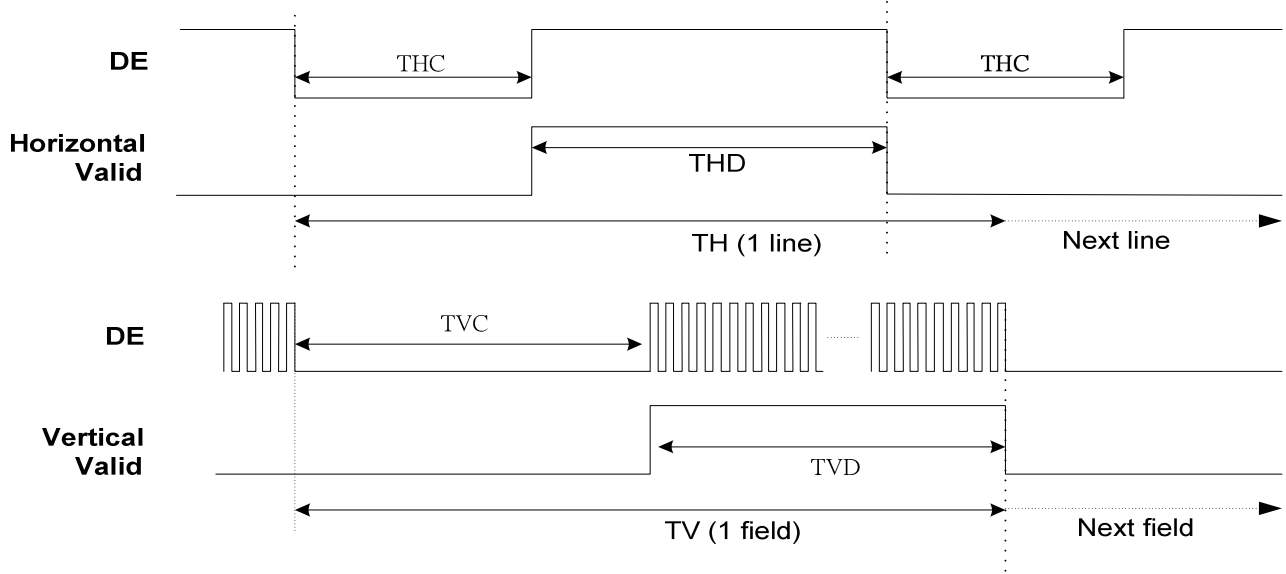

Fig.3-2 DE Model Input Timing

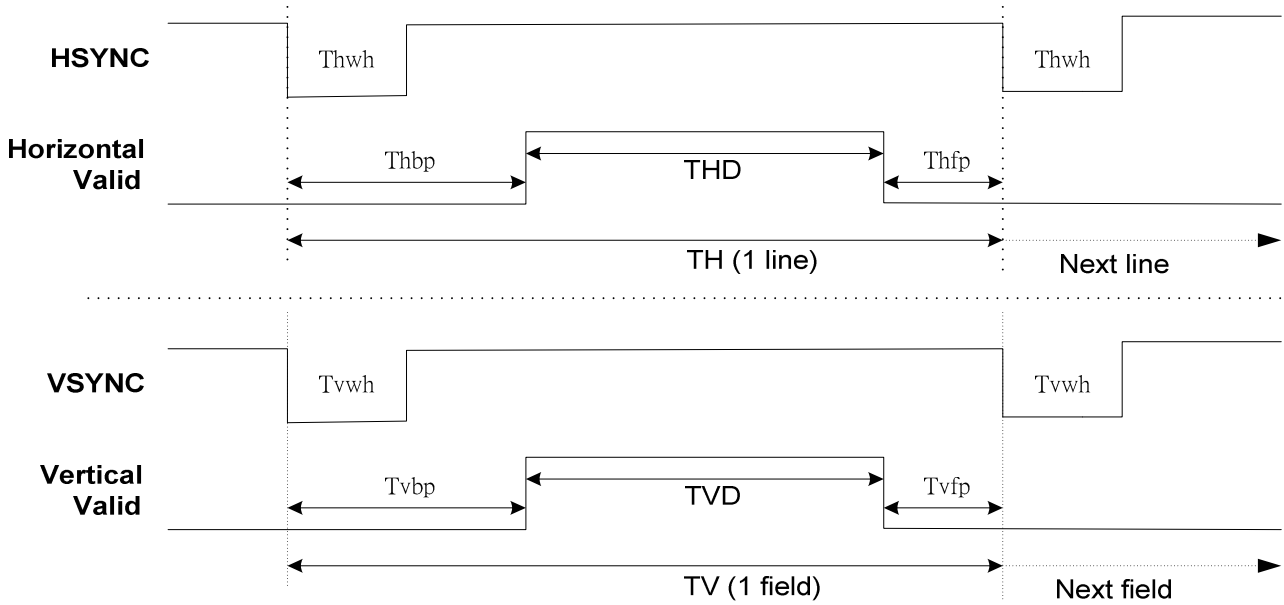

Fig.3-3 HV Model Input Timing

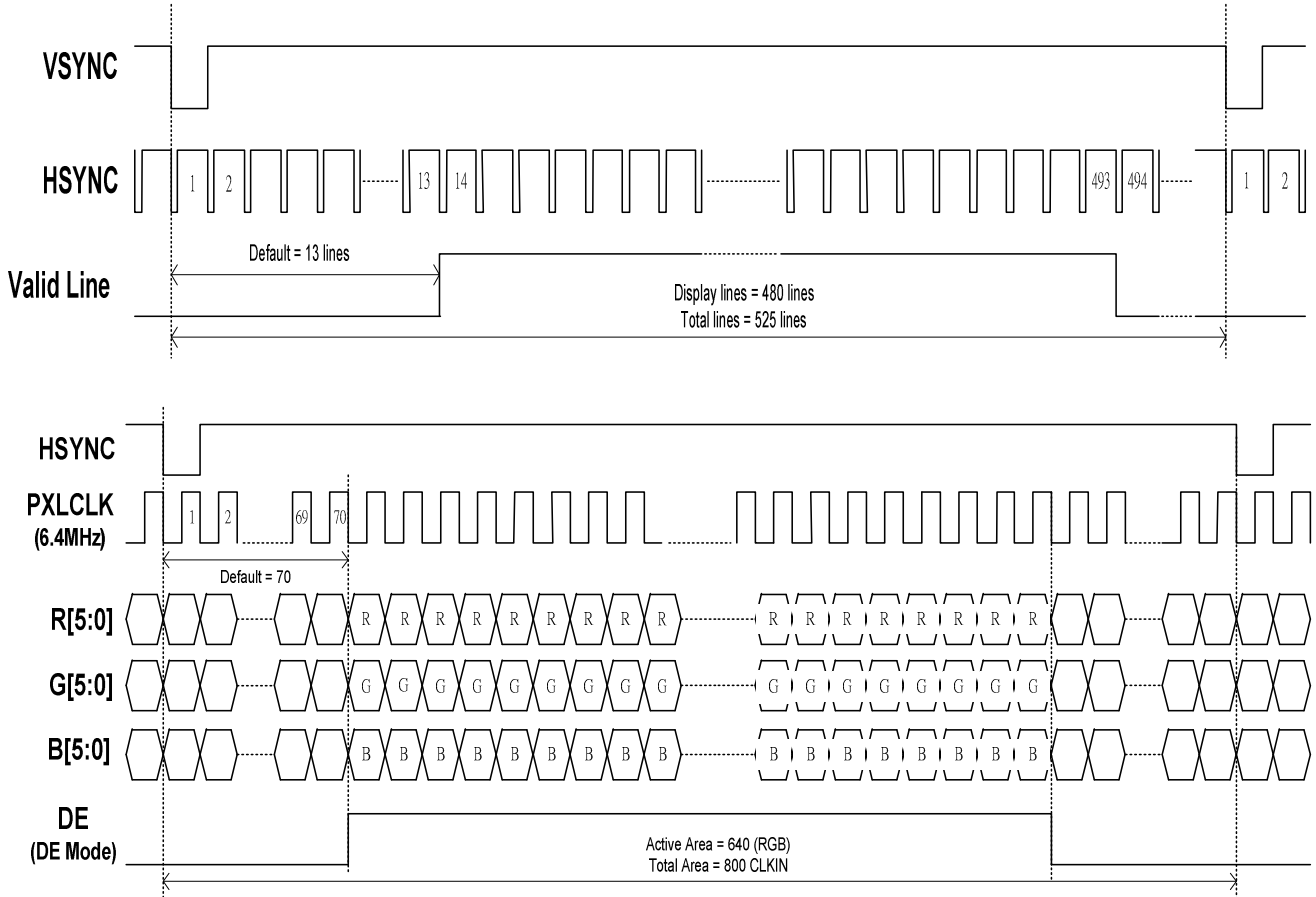

Fig. 3-4 18 bit RGB mode for 640 x(RGB)x 480

## 4. Optical Specifications

Item	Symbol	Condition	Values			Unit	Remark
			Min.	Typ.	Max.		
Viewing angle (CR≥10)	$\theta_L$	$\Phi=180^\circ$ (9 o'clock)	60	70	-	degree	Note 1
	$\theta_R$	$\Phi=0^\circ$ (3 o'clock)	60	70	-		
	$\theta_T$	$\Phi=90^\circ$ (12 o'clock)	40	50	-		
	$\theta_B$	$\Phi=270^\circ$ (6 o'clock)	60	70	-		
Response time	$T_{ON}$	Normal $\theta=\Phi=0^\circ$	-	10	20	msec	Note 3
	$T_{OFF}$		-	15	30	msec	Note 3
Contrast ratio	CR		450	500	-	-	Note 4
Color chromaticity	$W_X$		0.26	0.31	0.36	-	Note 2 Note 5
	$W_Y$		0.28	0.33	0.38	-	Note 6
Luminance	$L_1$		150	200	-	cd/m <sup>2</sup>	Note 6
Luminance uniformity	$Y_U$		70	75	-	-	Note 7

### Test Conditions:

1.  $V_{DD}=3.3V$ ,  $V_{LED}=5.0V$ ,  $I_L=20mA$ rms , the ambient temperature is 25°C.
2. The test systems refer to Note 2.

Note 1: Definition of viewing angle range

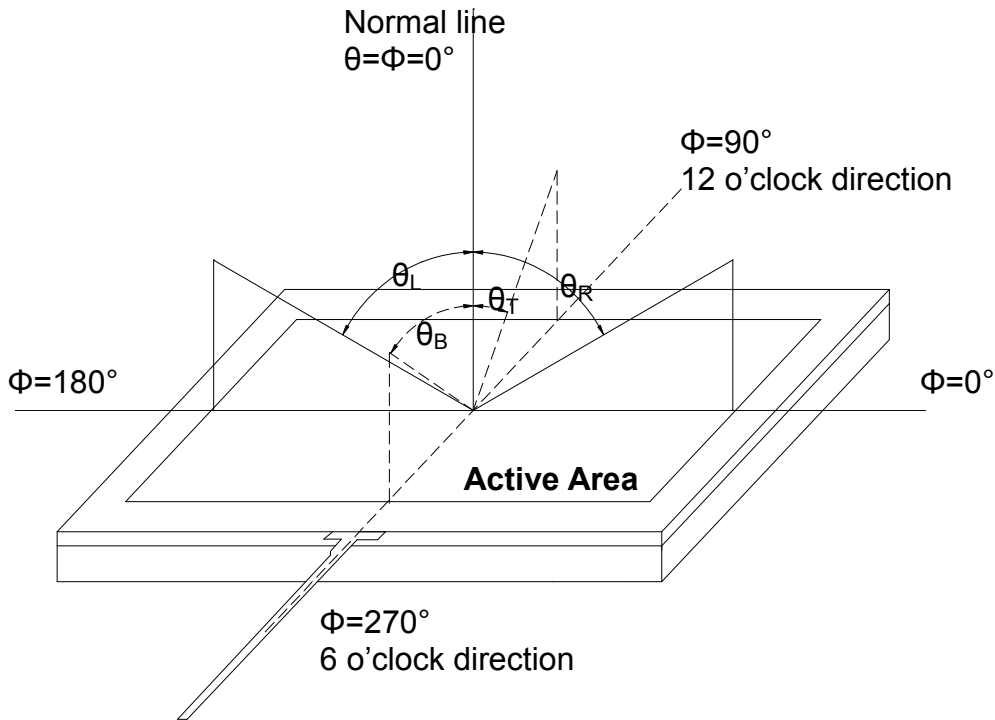

Fig. 4-1 Definition of viewing angle

Note 2: Definition of optical measurement system.

The optical characteristics should be measured in dark room. After 30 minutes operation, the optical properties are measured at the center point of the LCD screen. (Response time is measured by Photo detector TOPCON BM-7, other items are measured by BM-5A/Field of view:  $1^\circ$  /Height: 500mm.)

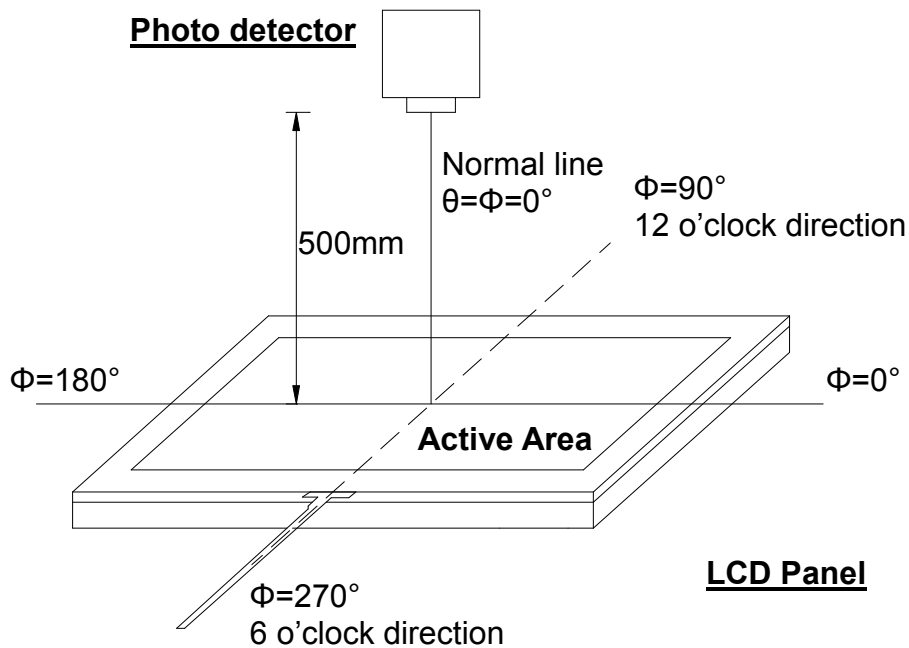

Fig. 4-2 Optical measurement system setup

**Note 3: Definition of Response time**

The response time is defined as the LCD optical switching time interval between “White” state and “Black” state. Rise time ( $T_{ON}$ ) is the time between photo detector output intensity changed from 90% to 10%. And fall time ( $T_{OFF}$ ) is the time between photo detector output intensity changed from 10% to 90%.

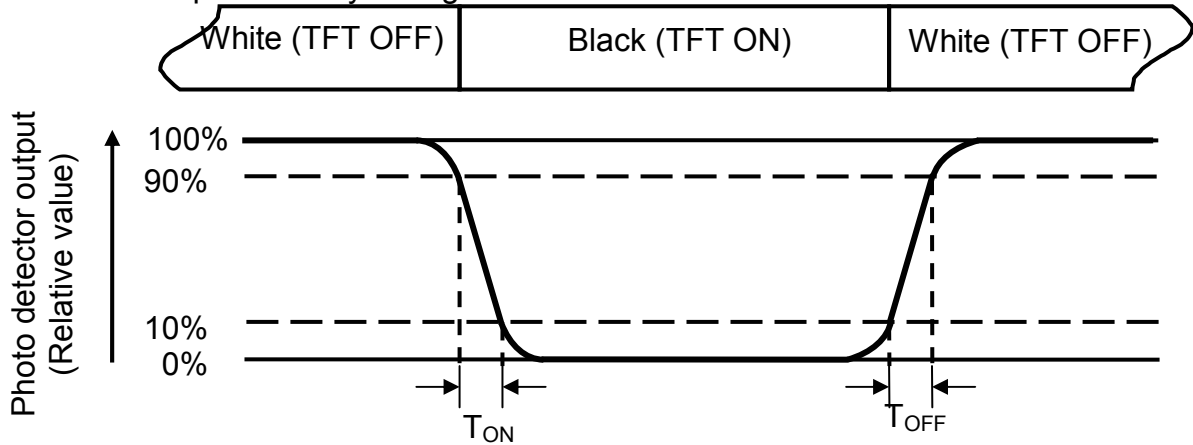

Fig. 4-3 Definition of response time

**Note 4: Definition of contrast ratio**

$$\text{Contrast ratio (CR)} = \frac{\text{Luminance measured when LCD is on the "White" state}}{\text{Luminance measured when LCD is on the "Black" state}}$$

White  $V_i = V_{i50\%} \pm 1.5 \text{ V}$

Black  $V_i = V_{i50\%} \mp 2.0 \text{ V}$

“±” means that the analog input signal swings in phase with  $V_{COM}$  signal.

“∓” means that the analog input signal swings out of phase with  $V_{COM}$  signal.

$V_{i50\%}$ : The analog input voltage when transmission is 50%

The 100% transmission is defined as the transmission of LCD panel when all the input terminals of module are electrically opened.

**Note 5: Definition of color chromaticity (CIE1931)**

Color coordinates measured at center point of LCD.

**Note 6:** All input terminals LCD panel must be ground while measuring the center area of the panel. And the brightness is defined at  $I_L = 20\text{mA}$ .

Note 7: Definition of Luminance Uniformity

Active area is divided into 9 measuring areas (Refer to Fig. 4-4 ).Every measuring point is placed at the center of each measuring area.

$$\text{Luminance Uniformity (Yu)} = \frac{B_{min}}{B_{max}}$$

L-----Active area length      W----- Active area width

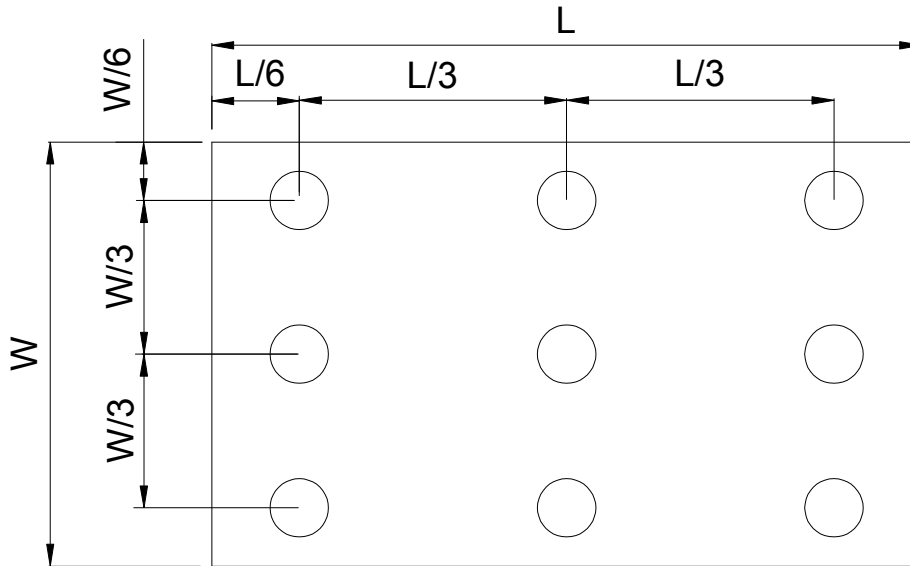

Fig. 4-4 Definition of measuring points

**B<sub>max</sub>**: The measured maximum luminance of all measurement position.

**B<sub>min</sub>**: The measured minimum luminance of all measurement position.



## 6. General Precautions

### 6.1. Safety

Liquid crystal is poisonous. Do not put it in your mouth. If liquid crystal touches your skin or clothes, wash it off immediately by using soap and water.

### 6.2. Handling

1. The LCD panel is plate glass. Do not subject the panel to mechanical shock or to excessive force on its surface.
2. The polarizer attached to the display is easily damaged. Please handle it carefully to avoid scratch or other damages.
3. To avoid contamination on the display surface, do not touch the module surface with bare hands.
4. Keep a space so that the LCD panels do not touch other components.
5. Put cover board such as acrylic board on the surface of LCD panel to protect panel from damages.
6. Transparent electrodes may be disconnected if you use the LCD panel under environmental conditions where the condensation of dew occurs.
7. Do not leave module in direct sunlight to avoid malfunction of the ICs.

### 6.3. Static Electricity

1. Be sure to ground module before turning on power or operating module.
2. Do not apply voltage which exceeds the absolute maximum rating value.

### 6.4. Storage

1. Store the module in a dark room where must keep at  $+25\pm 10^{\circ}\text{C}$  and 65%RH or less.
2. Do not store the module in surroundings containing organic solvent or corrosive gas.
3. Store the module in an anti-electrostatic container or bag.

### 6.5. Cleaning

1. Do not wipe the polarizer with dry cloth. It might cause scratch.
2. Only use a soft sloth with IPA to wipe the polarizer, other chemicals might permanent damage to the polarizer.

# 7.Mechanical Drawing

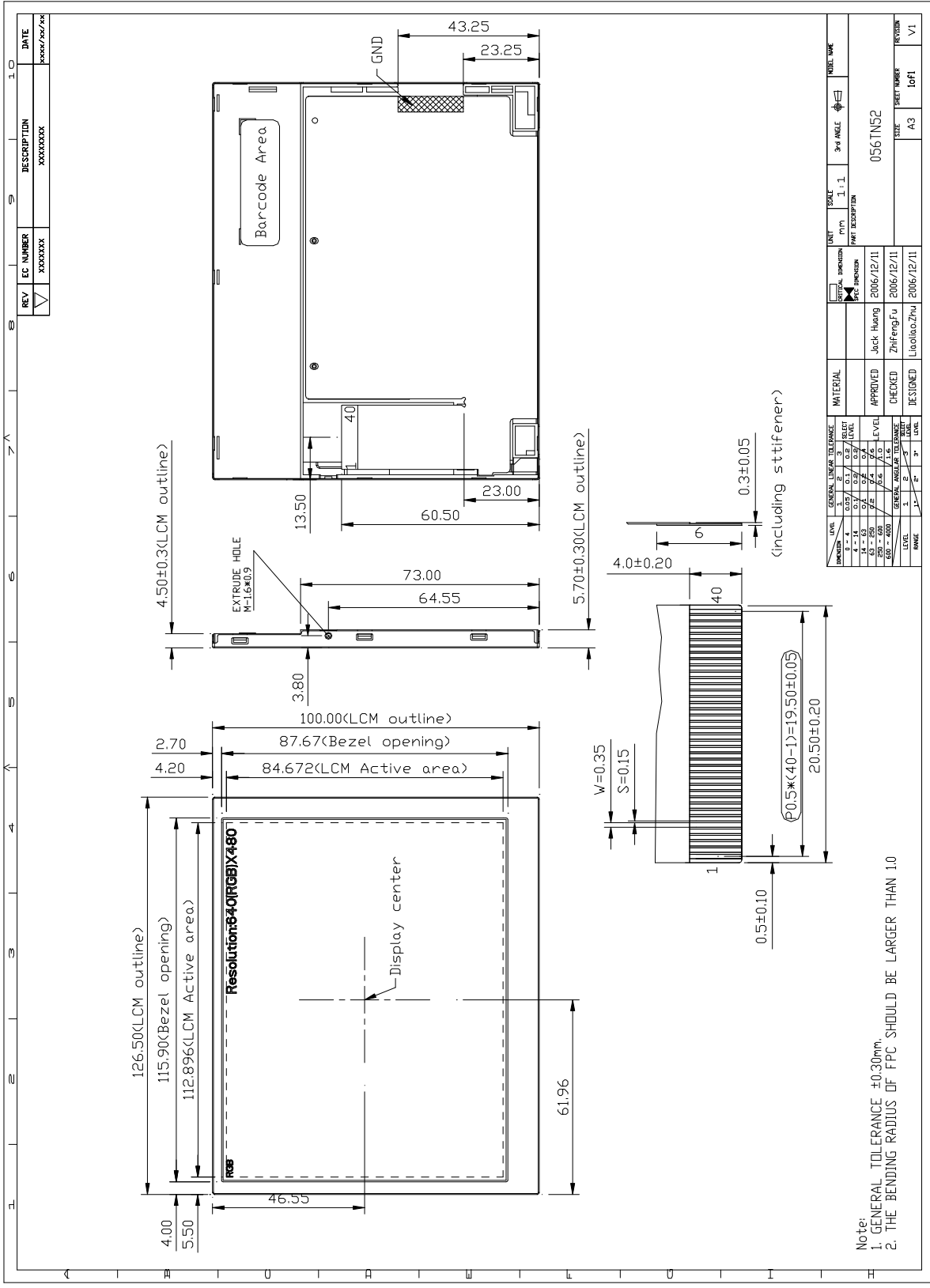

Note:  
 1. GENERAL TOLERANCE ±0.30mm.  
 2. THE BENDING RADIUS OF FPC SHOULD BE LARGER THAN 1.0

## 8.Package Drawing

TBD